

Owner's Manual

№ 51
Media
Player

Important Safety Instructions

1. Read and keep these instructions.
2. Heed all warnings.
3. Follow all instructions.
4. Do not use this apparatus near water.
5. Clean only with a dry cloth.
6. Do not install near any heat sources such as radiators, heat registers, stoves, or another apparatus that produces heat.
7. Do not defeat the safety purpose of the polarized or grounding-type plug. A polarized plug has two blades with one wider than the other. A grounding-type plug has two blades and a third grounding prong. The wide blade or third prong is provided for safety. If the provided plug does not fit into the outlet, consult an electrician for replacement of the obsolete outlet.
8. Protect the power cord from being walked on or pinched, particularly at plugs, convenience receptacles, or the point where it exits from the apparatus.
9. Only use attachments and accessories specified by the manufacturer.



10. Use only with the cart, stand, tripod, bracket, or table specified by the manufacturer or sold with the apparatus. When a cart is used, use caution when moving the cart/apparatus combination to avoid injury or tip over.

11. Unplug this apparatus during lightning storms or when unused for long periods of time.
12. Refer all servicing to qualified service personnel. Servicing is required when the apparatus has been damaged in any way, such as when the power cord or plug has been damaged; liquid has been spilled or objects have fallen into the apparatus; or the apparatus has been exposed to rain or moisture, does not operate normally, or has been dropped.
13. Ventilation should not be impeded by covering the ventilation openings with items such as newspapers, table cloths, curtains, and so on.
14. No naked flame sources, such as candles, should be placed on the apparatus.
15. The power cord is intended to be the safety disconnect device for this apparatus. Ready access to the power cord should be maintained at all times.



16. Terminals marked with this symbol may be considered HAZARDOUS LIVE and the external wiring connected to these terminals requires installation by an INSTRUCTED PERSON or the use of ready-made leads or cords

Warning!

To reduce the risk of fire or electric shock, do not expose this apparatus to rain or moisture. Apparatus shall not be exposed to dripping or splashing. No objects filled with liquids, such as vases, shall be placed on the apparatus. This unit employs a laser. Only a qualified service person should remove the cover or attempt to service this device, due to possible eye injury.

FCC Notice

This equipment has been tested and found to comply with the limits for a Class B digital device, pursuant to part 15 of the FCC Rules. These limits are designed to provide reasonable protection against harmful interference in a residential installation. This equipment generates, uses, and can radiate radio frequency energy and, if not installed and used in accordance with the instructions, may cause harmful interference to radio communications. However, there is no guarantee that interference will not occur in a particular installation. If this equipment does cause harmful interference to radio or television reception, which can be determined by turning the equipment off and on, the user is encouraged to try to correct the interference by one or more of the following measures:

- Reorient or relocate the receiving antenna.
- Increase the separation between the equipment and the receiver.
- Connect the equipment into an outlet on a circuit different from that to which the receiver is connected.
- Consult an authorized Mark Levinson dealer or an experienced radio/TV technician for help.

Caution!

Changes or modifications not expressly approved by the party responsible for compliance could void the user's authority to operate the equipment.

Canada

This Class B digital apparatus complies with Canadian ICES-003.

Cet appareil numérique de la classe B est conforme à la norme NMB-003 du Canada.



3 Oak Park
Bedford, MA 01730-1413 USA
Telephone: 781-280-0300
Fax: 781-280-0490
www.marklevinson.com

Customer Service

Telephone: 781-280-0300
Sales Fax: 781-280-0495
Service Fax: 781-280-0499

Product Shipments

16 Progress Road
Billerica, MA 01821-5730 USA

Part No. 070-17143 | Rev 0 | 03/06

"Mark Levinson" and the Mark Levinson logo are registered trademarks of Harman International Industries. U.S. patent numbers and other worldwide patents issued and pending.

HDCP and High-bandwidth Digital Content Protection are trademarks of Intel LLC.

DVI and Digital Video Interface are trademarks of the Digital Display Working Group.

"Dolby" and the double-D symbol are trademarks of Dolby Laboratories. Manufactured under license from Dolby Laboratories.

DTS and DTS Digital Surround are registered trademarks of Digital Theater Systems, Inc.

HDMI, the HDMI logo and High-Definition Multimedia Interface are trademarks or registered trademarks of HDMI Licensing LLC.

This product incorporates copyright protection technology that is protected by U.S. patents and other intellectual property rights. Use of this copyright protection technology must be authorized by Macrovision, and is intended for home and other limited viewing uses only unless otherwise authorized by Macrovision. Reverse engineering or disassembly is prohibited.

©2006 Harman International Industries, Incorporated. All rights reserved.

This document should not be construed as a commitment on the part of Harman International Industries, Incorporated. The information it contains is subject to change without notice. Harman Specialty Group assumes no responsibility for errors that may appear within this document.

Documentation Conventions

This document contains general safety and operation instructions for the N° 51 Media Player. It is important to read this document before attempting to use this product. Please pay particular attention to safety instructions.



Appears on the component to indicate the presence of non-insulated, dangerous voltages inside the enclosure – voltages that may be sufficient to constitute a risk of shock.



Appears on the component to indicate important operation and maintenance instructions included in the accompanying documentation.



Appears on the component to indicate compliance with the EMC (Electromagnetic Compatibility) and LVD (Low-voltage Directive) standards of the European Community.

Warning! *Calls attention to a procedure, practice, condition, or the like that, if not correctly performed or adhered to, could result in personal injury or death.*

Caution! *Calls attention to a procedure, practice, condition, or the like that, if not correctly performed or adhered to, could result in damage or destruction to part or all of the component.*

Note *Calls attention to information that is essential to highlight.*

Table of Contents

Section: 1 Getting Started

About the No51 Media Player	1-1
The Chassis	1-1
The Transport	1-1
The Power Supply	1-2
The Video Processor	1-2
The Audio Processor	1-3
Configurations	1-4
HDMI Configurations	1-4
Analog Video Configurations	1-5
Analog Audio Configurations	1-6
Digital Audio Configurations	1-8
Installation Considerations	1-9
Unpacking	1-9
Product Registration	1-9
Placement and Ventilation	1-9
Remote Control Batteries	1-10
Power Requirements	1-12
Power On from Power Button	1-12
Power On from Standby	1-12
Warm-up & Break-in Period	1-12
Disc Compatibility	1-13
Special Concerns for Writable Media	1-13
Discs to Avoid	1-14
Disc Care and Handling	1-14

Section: 2 Basic Operation

Front-Panel Overview	2-1
Front-Panel Display	2-4
Media Type (digits 1 to 4)	2-4
Title & Chapter (digits 5 to 12)	2-4
Time & Information (digits 13 to 20)	2-4
Rear-Panel Overview	2-6
Remote Control	2-9
Remote Control Functions	2-10

Section: 3 Setup Menu

Setup Menu	3-1
Setup Menu Navigation	3-1
Audio Setup	3-3
Outputs: HDMI Audio Preferences	3-3
Outputs: S/PDIF Audio Preferences	3-5
Outputs: Analog Audio Preferences	3-7
A/V Sync Delay	3-12
Reset Audio Settings	3-13
Video Setup	3-14
Video Output Switch	3-14
Select Source Profile	3-16
Edit Source Profile	3-16

Edit Display Profile: HDMI Out	3-20
Edit Display Profile: Comp. Out Prog. Scan	3-25
Edit Display Profile: Analog Out Stand. Def.	3-26
Default TV Standard	3-28
Test Images	3-28
Disc Parameters	3-31
Default Language.....	3-31
DRC.....	3-31
Play Auto Bookmarks.....	3-32
Angle Indicator Icon.....	3-32
General Parameters	3-33
Screen Saver.....	3-33
Rest. Fact. Defaults	3-33

Section: 4 Playback Controls

Navigating Disc Menus	4-1
Disc Menu Navigation	4-2
Selecting Disc Settings	4-3
audio	4-3
subtitle language	4-3
camera angle	4-4
zoom ratio	4-5
Playback Modes	4-6
Play	4-6
Pause	4-7
Stop	4-7
Resume	4-7
Slow Search (slow fwd/rev)	4-8
Fast Search (fwd/rev)	4-8
8s prev	4-9
Frame-by-frame	4-9
Search	4-10
Random	4-11
Repeat	4-12
A-B Repeat	4-13
Playlist	4-14
Playlist Requirements	4-15
Manual and Automatic Bookmarks	4-17
Info Mode	4-19
DVD-V Info status in Play, Pause, Resume or Stop mode ..	4-20
CD Info status in Play, Pause or Stop mode	4-21

Section: 5 Troubleshooting & Maintenance

Troubleshooting	5-1
No Power	5-1
No Remote Control Operation	5-1
No Main Output	5-2
No Video Output	5-2
No Audio and/or Video Output Using HDMI Output	5-2
If All Else Fails... ..	5-3

Restoring Factory-default Settings 5-3
Care & Maintenance 5-4

Appendix

Specifications A-1
Declaration of Conformity A-4
Audio Menu Tree A-5
Video Menu Tree A-6
Disc Menu Tree A-7
General Menu Tree A-7
Display Aspect Ratio A-8

1

Getting Started

About the N°51 Media Player

The N°51 Media Player is a milestone product for Mark Levinson. All-new in design, the N°51 Media Player combines a DVD-Video processor that provides extremely high-quality picture and sound for the ultimate in movie cinema reproduction, and a CD processor, capable of music playback that exceeds that of high-end stand-alone CD players.

There are five areas of design in the N°51; each carefully crafted element surpasses its design criteria and integrates seamlessly to create a product that performs well beyond the sum of its parts.

The Chassis

The N°51 Media Player front panel utilizes thick, machined aluminum, a combination of brushed and painted finishes, and laser-engraved artwork. The chassis cover is formed from a single piece of aluminum which incorporates a secondary shield to provide a seamless electro-magnetic barrier. The chassis itself is partitioned to provide electrical isolation for critical circuits where needed. In every respect, the N°51 is a product built to withstand the test of time.

1-1

The Transport

The heart of any media player is the transport. The N°51 starts with a solid cast aluminum frame for exceptional rigidity and stability. The media drawer is precision milled from aluminum and is mounted on polished stainless steel drawer guides.

The custom-designed loader assembly components include:

- The drive lift and rack-and-pinion drawer actuator, which uses special damping material to isolate the drawer from nearby components.
- Optical encoders, to send feedback to the motor control circuit, providing precise control over the drawer's motion.
- A shock-mounted transport frame, decoupled from the chassis and further isolated from the audio section and other sections of the player, to provide a better sound.

- A damper bridge, machined from solid aluminum to increase mass and rigidity and eliminate flexure from day-to-day operation and to promote stability in the physical mechanism.

All of these custom design attributes work in concert to provide smooth, quiet and consistent transport operation.

The Power Supply

The power supply is the foundation upon which the audio and video signals are built. The analog audio outputs utilize a dedicated power system consisting of a custom-designed low-noise toroidal transformer, a secondary analog power section which performs the first stage of regulation and filtering, followed by a final stage of local regulation in the output section itself.

Power to the digital audio and video sections is provided by a switch-mode power supply that delivers a single constant voltage, which is distributed to local modules where it is converted to the voltages required for each individual circuit. This “point of load” power distribution technique prevents unwanted interactions, caused by uneven supply, during periods of high demand from any single circuit. Another advantage is the efficient distribution of power reducing thermal dissipation to provide a more stable operating environment.

1-2

The Video Processor

The N°51 Media Player provides the video performance and flexibility that one expects from a Mark Levinson product. Custom calibrated scaling and de-interlacing are provided with support for resolutions up to 720p and 1080i. Other features include:

- Aspect ratio conversion to eliminate letterboxing and pillar boxing.
- High quality 14-bit / 216MHz video Digital-to-Analog Converters (DACs) provide exceptional video output for analog displays.
- An on-screen display, unique to the N°51, complements the elegance of its industrial design.

In addition to the standard analog video outputs, the N°51 includes a High-Definition Multimedia Interface (HDMI) output for use with digital display devices. By using the HDMI output with a high-definition digital display, the video signal remains in the digital domain from the source (disc) to the destination (display), unlike an analog system, where digital video signals are converted to analog and back to digital in the display, introducing unnecessary conversions and possible degradations of the picture.

The N°51 Media Player also features a separate monitor output for use with a media processor.

The Audio Processor

As in the N°40, the N°51 employs a Direct Digital Synthesis circuit incorporating a very high frequency reference clock. All data and clock signals carrying the digital audio information to the DACs are sent via a balanced Low Voltage Differential Signaling transmission line. This transmission scheme was first utilized in the N°40 Media Processor and N°390S CD Processor. The N°51 also has the ability to output 44.1, 48, 88.2, or 96kHz signals from the S/PDIF, AES or EIAJ outputs using a dedicated sample rate converter.

Digital-to-analog conversion in the N°51 is implemented using balanced multi-bit Sigma/Delta DACs delivering superb technical performance. In addition to the multi-bit architecture, these DACs have a differential current output, which allows optimization of the critical current-to-voltage conversion stage with dedicated operational amplifiers, possessing superlative rise time and bandwidth characteristics. Each channel incorporates two DACs in a dual-mono mode configuration. Following this, a custom active filter circuit sums both halves of the balanced signal and provides excellent common mode noise rejection in addition to outstanding audio characteristics. This approach to the digital-to-analog circuit topology yields extraordinarily low distortion, improved signal-to-noise ratio and superb, musical sound quality.

Following the active filters, the signal passes through the volume control. The N°51 volume control is built around a dual MDAC 12-bit ladder attenuator, derived from the N°40. Volume controls are a critical part of any audio product, and multi-channel audio is particularly demanding. Offsets in volume level between channels can be large, yet always need to be maintained in a precise relationship over the entire control range. The N°51 volume control uses a hybrid analog/digital attenuation scheme to achieve a remarkable 80dB control range at 0.1dB resolution from 20 to 80 dB and 1dB resolution from 0 to 20dB. By applying DSP-based digital attenuation only to fill in the gaps for the very lowest level volume control steps, the N°51 does not suffer the loss of resolution associated with pure digital volume controls.

For music reproduction, the N°51 offers separate, fully balanced front left and right outputs in addition to 5.1-channel outputs. Additional attention was given to these channels resulting in a design which maintains fully balanced signals from the digital-to-analog conversion stage to the output.

The N°51 represents the next step in the evolution of the Mark Levinson product line. It combines superb video and audio performance while remaining true to the core principles of Mark Levinson. It is designed to elevate the enjoyment of DVD-Videos and CDs to a remarkably high level. New features, such as HDMI, allow the stunning video quality of the N°51 to be appreciated, while the tried and true analog audio circuitry make it a remarkably musical product. The N°51 Media Player owner can take pride in knowing that they have purchased the finest instrument available for the enjoyment of their film and music collections.

Configurations

HDMI Configurations

Nº51 HDMI Video and Audio Output

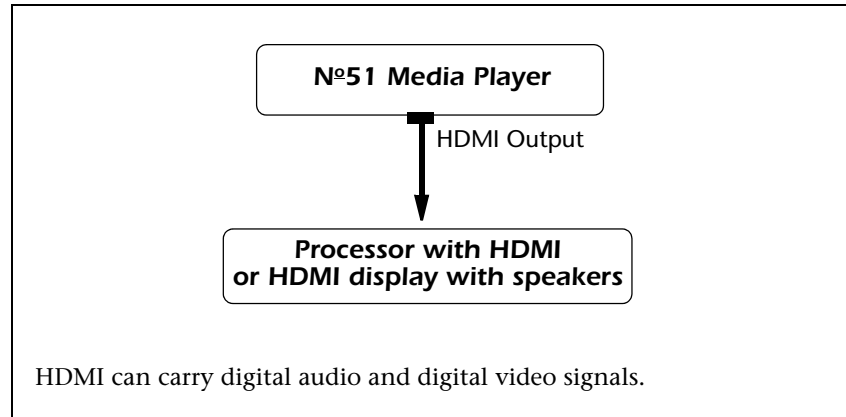

Nº51 HDMI Video and S/PDIF, AES or EIAJ Digital Audio Output

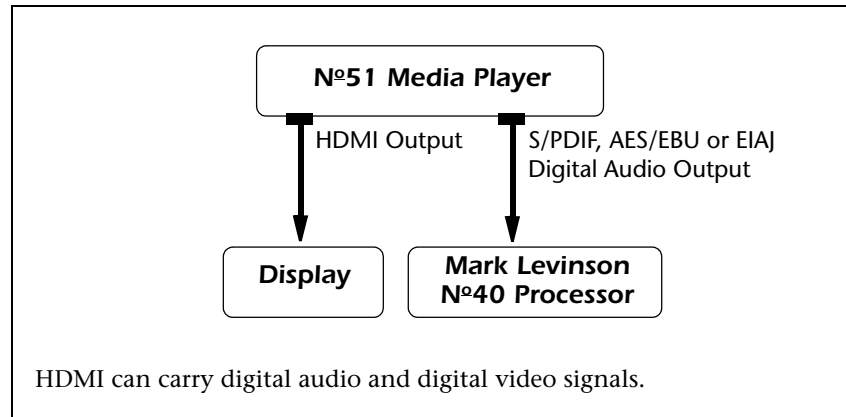

1-4

Alternately, an HDCP compatible DVI monitor can be connected to the Nº51 HDMI output for the last two HDMI configurations on this page. Note that DVI carries digital video only.

Nº51 HDMI Video and Analog Audio Output

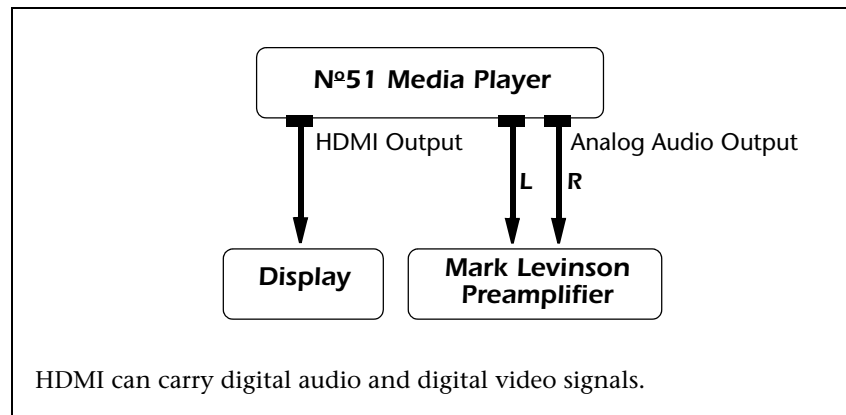

Analog Video Configurations

N°51 SCART Output to Device with SCART Video Inputs

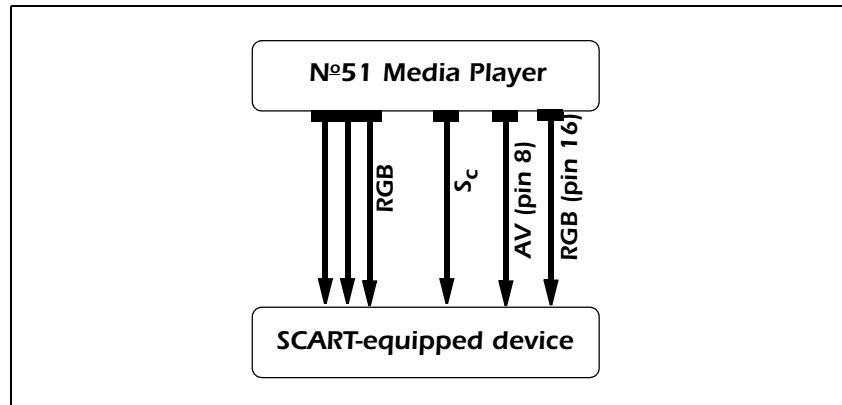

Set the Video Format parameter to Analog RGB in the Analog Out Stand. Def. section of the Edit Display Profile menu when using the component outputs with a SCART RGB monitor.

N°51 Analog Video Output to Display or Mark Levinson Media Console

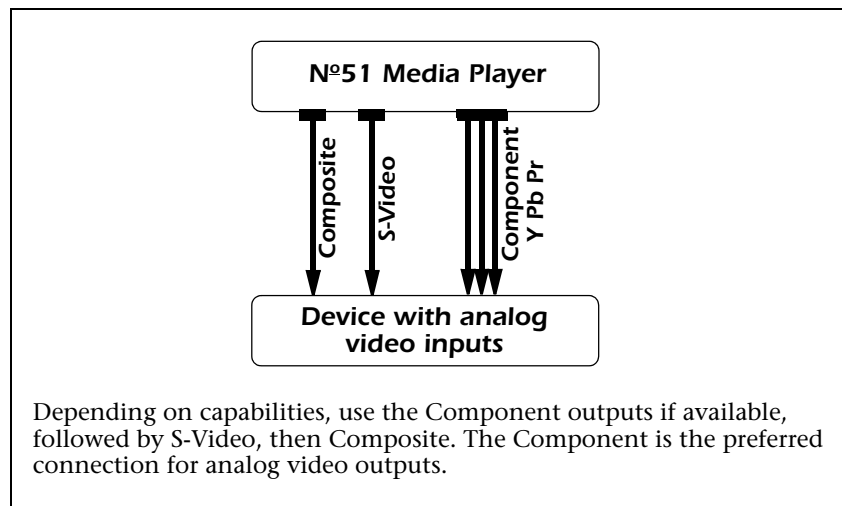

1-5

Monitor Output

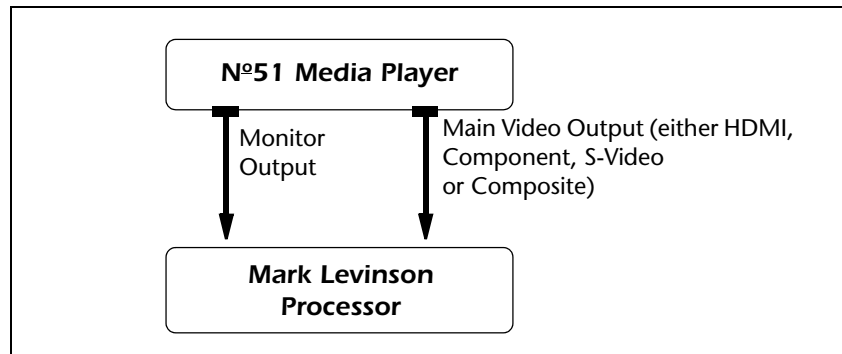

The Monitor output always provides video output at 480i or 576i depending on the disc (with no OSD) regardless of the position of the rear panel Video switch.

This dedicated output is provided to ensure a video output that is compatible with the front panel display of the N°40 is always available, even when the primary video output is configured for a higher resolution setting (for example, 1080i).

Analog Audio Configurations

5.1 Analog Audio Outputs Direct to Power Amplifier

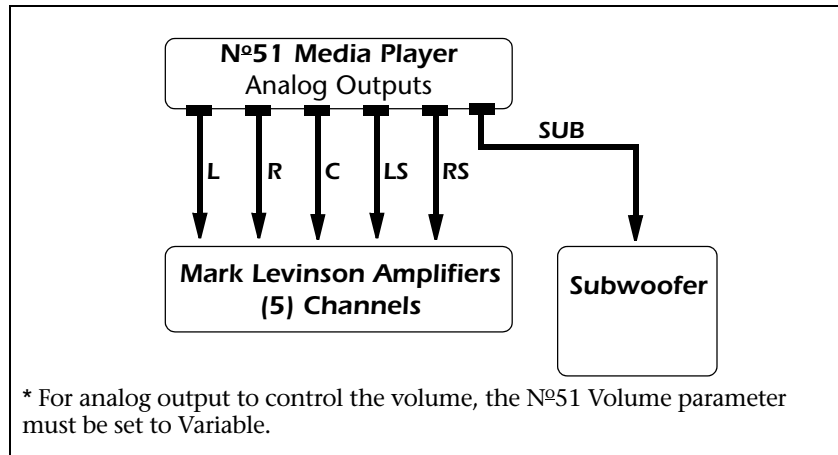

1-6

- Set the **Volume Control : Volume** parameter to “Variable” to directly control the signal level to the power amp using the N°51 remote (page 3-11).
- Multichannel audio is output using the “6 Channel Analog Output” connectors. Select **Analog Audio Preferences : 5.1 CH** to configure multichannel audio preferences.

5.1 Analog Outputs to Digital Audio Processor

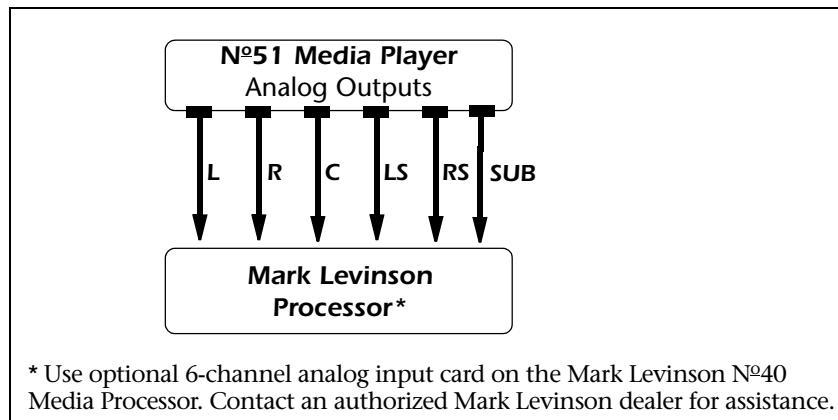

- Set the **Volume Control : Volume** parameter to “Fixed” to output a fixed line-level signal, and use the N°40 to control the volume level (page 3-11).

- In this configuration, multichannel audio is output using the “6 Channel Analog Output” connectors. Select **Analog Audio Preferences : 5.1 CH** to configure multichannel audio preferences.

SSP Mode Using Analog Audio Outputs

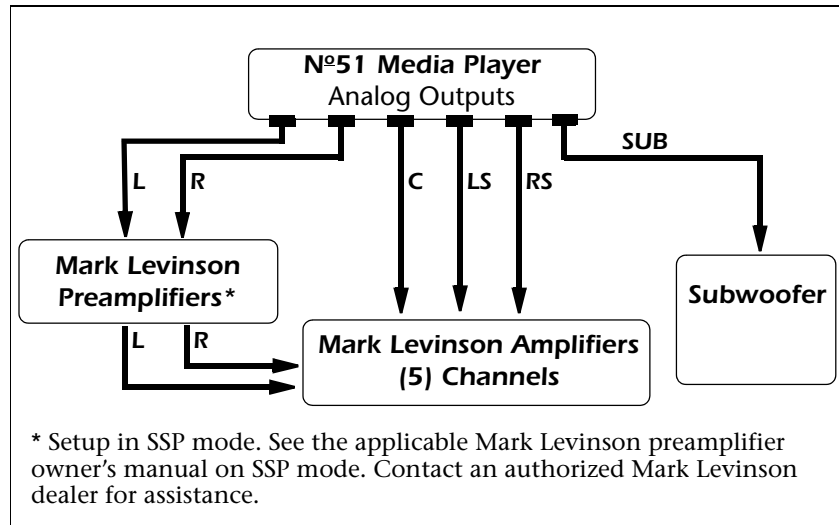

- Set the **Volume Control : Volume** parameter to “Variable” to directly control the signal level to the power amplifier using the N°51 remote (page 3-11).
- In this configuration, multichannel audio is output using the “6 Channel Analog Output” connectors. Select **Analog Audio Preferences : 5.1 CH** to configure multichannel audio preferences.

1-7

2-Channel Analog Outputs to Preamplifier

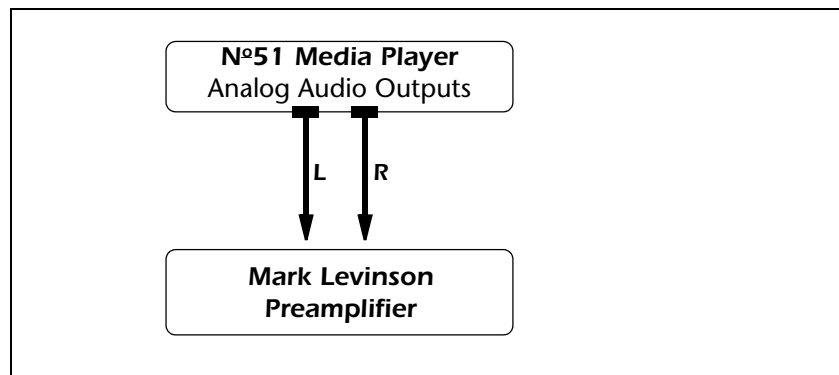

- Set the **Volume Control : Volume** parameter to “Fixed” to output a fixed line-level signal, and use the Mark Levinson preamplifier to control the volume level (page 3-11).
- Select **Analog Audio Preferences : 2-CH** to configure the N°51 to downmix all multichannel audio sources to 2-channel analog.

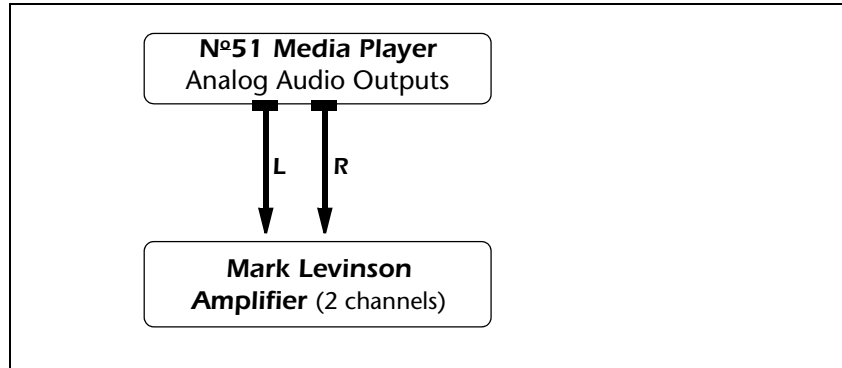
2-Channel Analog Output Direct to Power Amplifier

- Set the **Volume Control : Volume** parameter to “Variable” to directly control the signal level to the power amplifier using the N°51 remote (page 3-11).
- Select **Analog Audio Preferences : 2-CH** to configure the N°51 to downmix all multichannel audio sources to 2-channel analog.

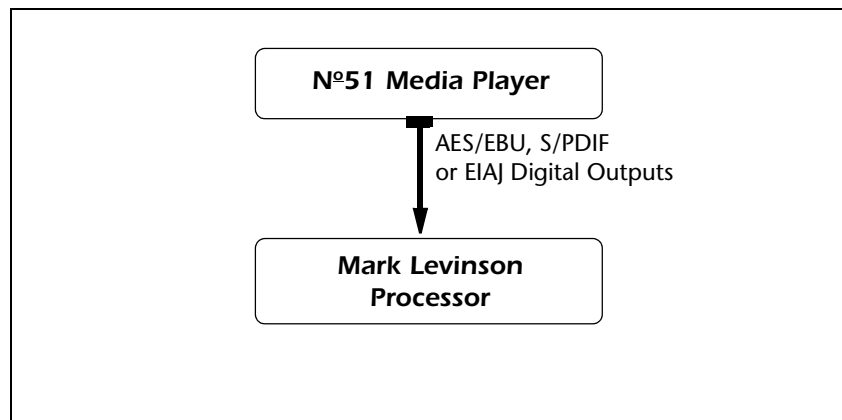
Digital Audio Configurations**Digital Audio Output to a Digital Audio Processor**

Installation Considerations

The N°51 Media Player requires special care during installation to ensure optimal performance. Pay particular attention to instructions included in this section and to precautions included throughout this owner's manual.

Unpacking

When unpacking:

DO save all packing materials for possible future shipping needs.

DO inspect the media player for signs of damage during shipment. If damage is discovered, contact an authorized Mark Levinson dealer for assistance making appropriate claims.

DO locate and remove the accessory box from the carton. Make sure it contains all of the items listed in the table below. If not, contact an authorized Mark Levinson dealer.

Item	Quantity
Detachable AC power cord	1
N°51 remote control	1
Phillips screwdriver	1
N°51 Owner's Manual (this document)	1
AAA alkaline batteries*	2
White gloves**	1
Warranty & Product Registration Card	1

* The remote control comes with two AAA alkaline batteries that should be replaced as needed.

** One pair of white gloves is provided to assist with the initial unpacking and installation of the media player.

1-9

Product Registration

Please register the media player within 15 days of purchase. To do so, register online at www.marklevinson.com or complete and return the included product registration card. Retain the original, dated sales receipt as proof of warranty coverage.

Placement and Ventilation

DO install the media player on its own shelf for proper ventilation.

DO install each media player chassis on a solid, flat, level surface.

DO install the media player close to associated components to keep interconnecting cables as short as possible.

DO select a dry, well-ventilated location out of direct sunlight.

DO allow at least 3 to 4 inches (8 to 10cm) of clearance above each component for proper heat dissipation.

DO NOT place the media player on a thick rug or carpet or cover the media player with a cloth, as this might prevent proper cooling.

DO NOT expose the media player to high temperatures, humidity, steam, smoke, dampness, or excessive dust. Avoid installing the media player near radiators and other heat-producing appliances.

DO NOT install the media player near unshielded TV or FM antennas, cable TV decoders, and other RF-emitting devices that might cause interference.

DO NOT place the media player on a windowsill or in another location in which it will be exposed to direct sunlight.

DO NOT obstruct the IR (infrared) receiver/transmitter located on the front-panel display. The remote control IR transmitter must be in line of sight with the front panel display IR receiver/ transmitter for proper remote control operation.

1-10

Caution!

BEFORE moving the media player, make sure it is powered off with the power button. Then, make sure the power cord is disconnected from the ~ac mains connector and the electrical outlet.

Warning!

MAKE SURE all components are properly grounded. Do not defeat the safety purpose of polarized or grounding-type plugs with "ground-lifter" or "cheater" adaptors. Doing so may cause dangerous voltages to build up between components. The presence of these voltages may result in personal injuries and/or product damage.

Remote Control Batteries

The remote control comes with two AAA alkaline batteries that should be replaced as needed. Using alkaline batteries, which last longer and do not leak, is recommended.

To install the remote control batteries:

1. Locate the battery compartment cover on the bottom of the remote control (the end closest to the IR transmitter).

2. Using a Phillips screwdriver, remove the two screws from the battery compartment cover, then remove the cover.
3. Remove the old batteries in the battery compartment.
4. Insert two AAA alkaline batteries. Make sure the batteries are correctly inserted observing the proper polarity.



5. Align the battery compartment cover with the guide on the bottom of the remote control.
6. Replace the two screws removed in step 2.
7. Properly dispose of the old batteries.

Power Requirements

When shipped, the media player is configured for 100, 120, 220 or 230-240VAC power operation at 50 or 60Hz. Before operating the media player, make sure the ~ac mains connector label indicates the correct operating voltage for the current location.

Caution!

DO NOT attempt to adjust the operating voltage. Consult an authorized Mark Levinson dealer if the operating voltage is incorrect or must be changed for relocation purposes.

Different operating voltages may require the use of different power cords and/or attachment plugs. Contact an authorized Mark Levinson dealer for additional assistance.

Power On from Power Button

When powered on with the power button, the main output connectors mute while the media player executes its initialization sequence. The media player automatically enters standby after completing its initialization sequence.

1-12

Power On from Standby

The media player should be unplugged during lightning storms and during extended periods of non-use. Otherwise, it is designed for continuous operation. For best performance, make sure power is connected to the media player at all times. During normal operation, do not use the power button to power off the media player. Standby places the media player in a low-power mode that conserves energy.

Warm-up & Break-in Period

Although the media player delivers superior performance from the first time it is powered on, this performance will continue to improve as the media player reaches its normal operating temperature and various components “break in.” The greatest performance improvements will occur within the first 25 to 50 hours of use. Sound quality will continue to improve for about 300 hours.









After this initial period, performance will remain consistent unless power is disconnected from the media player.

Power is disconnected when the media player is powered off with the power button; the power cord is disconnected from the ~ac mains connector or the electrical outlet; or an extended power failure or power outage occurs. Power is not disconnected when the media player is in standby.

When power returns, it is recommended to allow the media player and other audio components to stabilize for about 2 minutes. The media player will require a brief warm-up and break-in period (not the full 300 hours).

Disc Compatibility

The N°51 Media Player is compatible with disc formats that meet the requirements listed in the table below.

Disc Format	Logo	Compatibility Requirements
DVD-V		<ul style="list-style-type: none"> • 5-inch (12cm) or 3-inch (8cm) discs • Dolby Digital, DTS or PCM (Linear) digital audio • Single- or double-sided discs • Single- or dual-layered discs
DVD-R		<ul style="list-style-type: none"> • 5-inch (12cm) or 3-inch (8cm) discs • Discs recorded in DVD-V format
DVD-RW		<ul style="list-style-type: none"> • 5-inch (12cm) or 3-inch (8cm) discs • Discs recorded in DVD-V format
DVD+R		<ul style="list-style-type: none"> • 5-inch (12cm) or 3-inch (8cm) discs • Discs recorded in DVD-V format
DVD+RW		<ul style="list-style-type: none"> • 5-inch (12cm) or 3-inch (8cm) discs • Discs recorded in DVD-V format
AUDIO CD		<ul style="list-style-type: none"> • 5-inch (12cm) or 3-inch (8cm) discs
CD-R		<ul style="list-style-type: none"> • 5-inch (12cm) or 3-inch (8cm) discs • Discs recorded in Audio CD format
CD-RW		<ul style="list-style-type: none"> • 5-inch (12cm) or 3-inch (8cm) discs • Discs recorded in Audio CD format
DTS CD		<ul style="list-style-type: none"> • 5-inch (12cm) or 3-inch (8cm) discs

1-13

Special Concerns for Writable Media

Results can be unpredictable when using copies of prerecorded media because of copyright protection on the original disc.

Discs to Avoid

The N°51 Media Player is compatible with 5-inch (12 cm) and 3-inch (8 cm) conventional, round discs. Do not attempt to load discs with other size and shape characteristics. All discs must align with one of the circular guides inside the disc drawer.

Disc Care and Handling

Discs require special care and handling to ensure optimal performance. Pay particular attention to the following:

DO hold discs at their center hole and outer edges. Take care not to leave fingerprints, dirt, and scratches on the disc surfaces.

DO load single-sided discs with the label side facing upward and double-sided discs with the side intended for playback facing downward. All loaded discs must align with the circular guide inside the disc drawer.

DO return discs to their cases when not in use. Discs should be stored in an upright position out of direct sunlight and excessive heat, humidity, or cold.

DO NOT write on disc labels or surfaces with ballpoint pens, pencils, or other sharp-tipped writing instruments. Do not glue paper or attach stickers to discs. Although not as fragile as the recorded side, damage to the label side of the disc can render the disc unplayable.

1-14

Caution!

The N°51 is a single-disc player. Do not attempt to insert more than one disc in the disc drawer at one time. This might cause damage to the player, the discs, or both.

Dirty or damaged discs might affect playback performance or damage the player. Do not attempt to load cracked, chipped, scratched, warped, dirty, or otherwise damaged discs in the disc drawer.

2

Basic Operation

Front-Panel Overview

The numbers in the front-panel illustration shown in Figure 2-1 correspond with the summary list items below.

Figure 2-1: N°51 Media Player front-panel

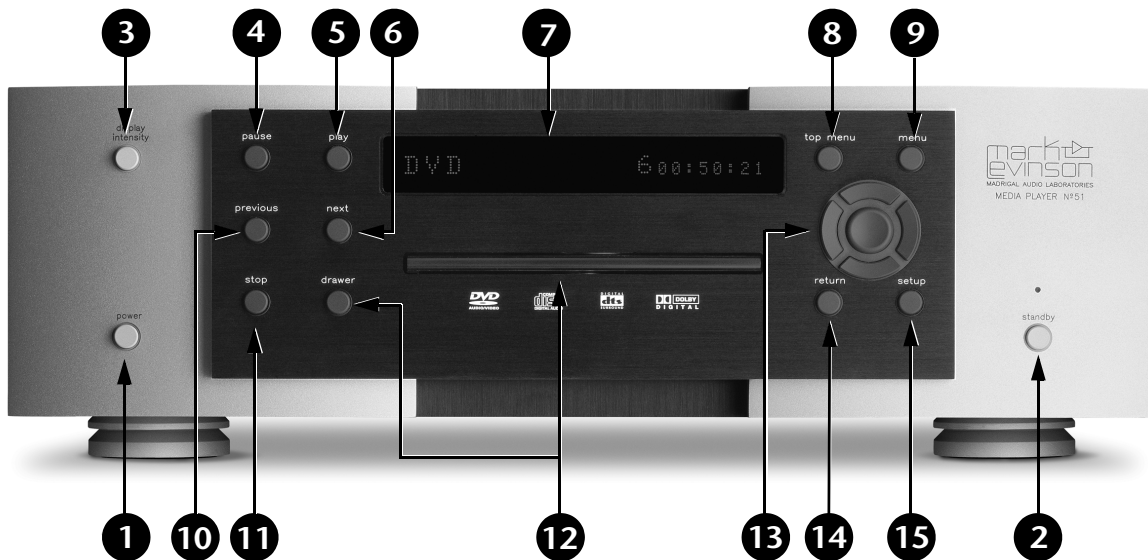

2-1

1. **power** button
2. **standby** button and LED
3. **display intensity** button
4. **pause** button
5. **play** button
6. **next** button
7. **front-panel display**
8. **top menu** button
9. **menu** button
10. **previous** button
11. **stop** button
12. **drawer & drawer** button
13. **4-way/enter** button
14. **return** button
15. **setup** button

Below is a description of each item listed above. Unless otherwise specified, the following descriptions are of commands accessed from the front panel during normal operation.

1. power button

Powers the media player on and off when the supplied power cord is connected to the ~ac mains connector and an electrical outlet.

- When the media player is powered off, pressing the power button powers the media player on and connects power to the component. The media player automatically enters standby after completing its initialization sequence.
- When the media player is powered on or in standby mode, pressing the power button powers the media player off and disconnects power from the component.

Note

Before operating the media player, make sure the voltage label near the ~ac mains connector (page 2-7) indicates an operating voltage that is compatible with the voltage at the electrical outlet.

2. standby button & LED

2-2

When the media player is powered on, press the **standby** button to place the media player into or out of standby mode. When powered off, pressing the standby button has no effect. The standby red LED remains lit when the media player is receiving power while in standby mode.

3. display intensity button

Controls the illumination level of front-panel display characters. Pressing the **display intensity** button cycles the display intensity through the following settings: 100%, 75%, 50%, 25% and Off. When "Off", the display lights for a few seconds whenever a setting is changed.

4. pause button

Pauses and resumes playback. Pausing playback at the current position allows viewing of a single frame. Pressing **pause** when playback is in pause mode, resumes playback.

5. play button

Starts playback:

- From beginning of a disc if just loaded, or from where **stop** was pressed.
- At current position if **pause** was pressed.
- From standby mode.

6. next button

Press the **next** button to skip to the next chapter or track. If the player is in pause mode, the player skips to the next chapter or track, but remains in pause mode until the **play** button is pressed. Press-and-hold the **next** button to skip forward at 4x speed; release the button to resume playback at normal speed.

- 7. front-panel display** Displays 20 alphanumeric characters that allow viewing of status information. The right side of the front-panel display includes an IR receiver/transmitter that receives infrared commands from the remote control IR transmitter when the N°51 is not using the IR input connector.
- 8. top menu button** Displays the top level disc menu in the on-screen display. If the main menu of a DVD is playing and the top menu button is pressed, the DVD resumes playback at the last position.
- 9. menu button** Activates or deactivates the current disc menu. When playing an Audio-CD, pressing the menu button displays the track list. If the main menu of a DVD is playing and the menu button is pressed, the DVD resumes playback at the last position.
- 10. previous button** Press the **previous** button in play mode to start playback from the beginning of the current chapter or track. Repeatedly press the previous button to jump back to a previous chapter or track. Press and hold the previous button to search backward at 4x speed; release the button to resume playback at normal speed.
- 11. stop button** Stops playback. When playing a DVD, it is necessary to press the **stop** button twice to stop playback; pressing the stop button once stops playback at the current position.
- 12. drawer & drawer button** Press the **drawer** button to open or close the single-disc drawer. The drawer button can also be used to place the player out of standby mode, or to remember the current playback location by setting an automatic bookmark when the disc is ejected. For more information, see “Manual and Automatic Bookmarks” on page 4-17.
- 13. 4-way/enter button** The 4-way button (up, down, left and right) along with the enter and return buttons provide navigation control for the OSD (on-screen display) and disc menus. For more information, see “Disc Menu Navigation” on page 4-2.
- 14. return button** When navigating the OSD and disc menus, the **return** button is used to backtrack through the OSD menu hierarchy level-by-level. Unsaved changes are not saved when the return button is activated.
- 15. setup button** Opens and closes the Setup menu. For more information, see “Setup Menu” on page 3-1.

Front-Panel Display

The front-panel display provides one-line viewing of status information for the media player and currently loaded disc.

Figure 2-2: front-panel display

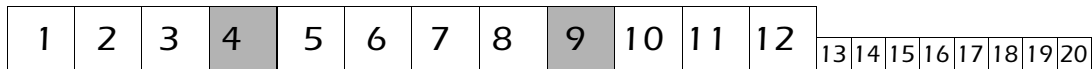

The display consists of 12 large and 8 small digits.

Digit	Typical usage
1 to 4	<ul style="list-style-type: none"> media type
5 to 12	<ul style="list-style-type: none"> title (7-8) chapter/track (10-12) information; for example PLAYLIST
13 to 20	<ul style="list-style-type: none"> time (HH:MM:SS) information; for example, USE OSD

2-4

Media Type (digits 1 to 4)

Digit fields 1 to 4 display the currently loaded media type. The following table shows how the different disc formats are displayed in the front-panel display digit fields 1 to 4.

Disc	Front-panel display text
DVD-V	DVD
Audio CD	CD
DTS CD	CD

Title & Chapter (digits 5 to 12)

Digit fields 5 to 12 normally display the current title (7-8) and chapter/track (10-12). In some cases, these fields are used to display other information; for example, PLAYLIST.

Time & Information (digits 13 to 20)

Digit fields 13 to 20 normally display the current playback time. In some cases, these fields are used to display text information; for example, USE OSD.

Most text information in the front-panel display is not abbreviated. The following table lists abbreviations that are used in front-panel display fields 5-12. For more information, see “Info Mode” on page 4-19.

RDM PLAY	Random Play
RDM OFF	Random Off
RDM TRK	Random Track
RPT CHP	Repeat Chapter
RPT DISC	Repeat Disc
RPT PLAY	Repeat Play
RPT OFF	Repeat Off
RPT TRK	Repeat Track
RPT TTL	Repeat Title
MARK RCL	Mark Recall

Front-panel display examples:

Figure 2-3: Front-panel display with a CD playing

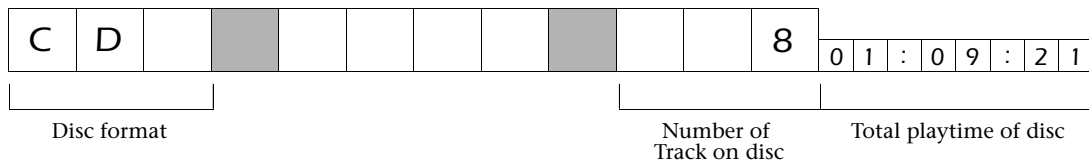

2-5

Figure 2-4: Front-panel display after pressing stop once with a DVD-V with resume mode

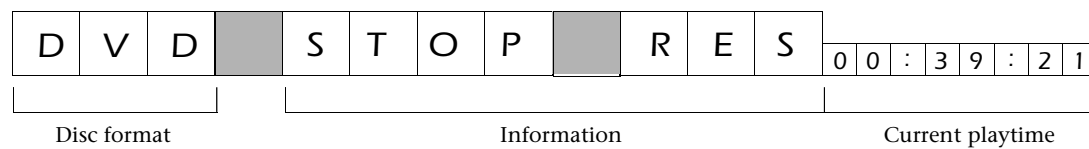
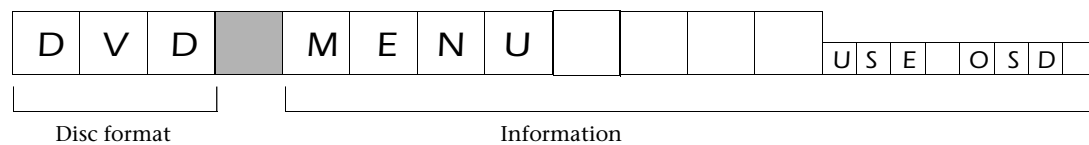

Figure 2-5: Front-panel display showing a DVD disc menu.



Rear-Panel Overview

The numbers in the rear panel illustration shown in Figure 2-6 correspond with the summary list items below.

Figure 2-6: N°51 Media Player rear panel

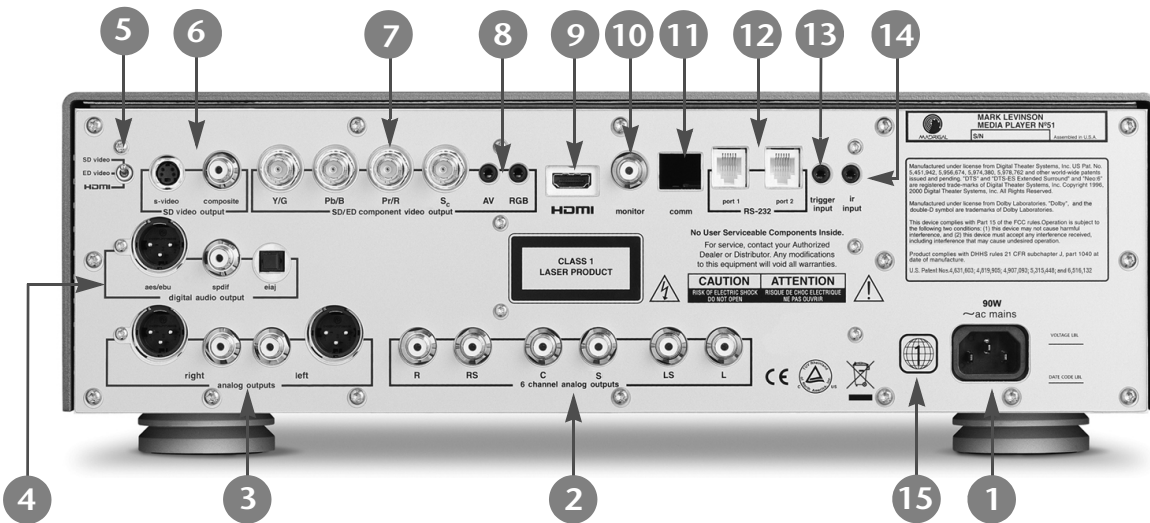

2-6

1. **ac mains** power connector
2. **6-channel analog output** connectors
3. **analog audio output** connectors
4. **digital audio output** connectors
5. **video output** switch
6. **S-Video/composite video output** connectors
7. **SD/ED component video output** connectors
8. **AV & RGB** mini jacks
9. **HDMI** connector
10. **monitor** connector
11. **comm** port
12. **RS-232** ports
13. **trigger input** connector
14. **IR input** connector
15. **region code** indicator

Below are descriptions of the connectors and ports listed above.

- 1. ac mains power connector**

Provides power to the N°51 when the supplied power cord is connected to the ac mains connector and an electrical outlet. One IEC-standard AC mains receptacle labeled ~ ac mains is available.

Before operating the N°51, make sure the voltage label near the ~ac mains connector indicates an operating voltage that is compatible with the voltage at the electrical outlet.
- 2. 6-channel analog output connectors**

Provide 6-channel analog audio output. Includes 6 RCA connectors labeled R (right front), RS (right surround), C (center), S (subwoofer), LS (left surround), and L (left front).
- 3. analog audio output connectors**

Provide stereo left-channel and right-channel output. Two balanced (male XLR) and two unbalanced (RCA) stereo output connectors are available.
- 4. digital audio output connectors**

Provide digital audio output. Includes one AES/EBU (XLR) output connector, one S/PDIF (coax) and one EIAJ (optical) output connector.
- 5. video output switch**

Switches video output to the corresponding connectors:

 - **SD video** (top) – S-Video, Composite, and Component (480/576i)
 - **ED video** (middle) – Component (480/576p)
 - **HDMI** (bottom) – HDMI (1080i, 720p, 480/576i, 480/576p)
- 6. S-Video & composite video output connectors**

Provide S-Video or Composite video output. Includes one S-Video connector and one RCA connector. S-Video transmits the chrominance (color) and luminance (brightness) video components using separate paths. Composite video combines chrominance and luminance and sends it through a single cable. S-Video connections result in a sharper picture than composite video.
- 7. SD/ED component video output connectors**

SD/ED (Standard Definition/Extended Definition) connectors provide progressive-scan and interlaced component video output.

Progressive-scan component video output converts interlaced video signals to progressive video signals, doubling the amount of video information. The result is a higher quality, more stable image with fewer video artifacts. Includes connectors labeled Y/G, Pb/B, Pr/R and S_c.
- 8. AV & RGB mini jacks**

The AV and RGB mini jacks are trigger outputs that are intended to work with mini plug to SCART (European) connectors. The AV trigger sends a message to the display device to indicate the appropriate aspect ratio—4:3, 16:9 or Off. The RGB trigger sends a message to the display device for the

appropriate video format—CVSB (Composite), S-Video or RGB. Each mini-jack requires a mini-plug (Tip/Sleeve) connection. See your Mark Levinson dealer for more information.

9. HDMI connector

High Definition Multimedia Interface multi-pin connector for passing standard and high definition digital video signals and both compressed and uncompressed digital audio streams. Uses HDCP (High-bandwidth Digital Content Protection).

10. monitor connector

Provides composite output, without on-screen display, to a video monitor.

11. comm

Reserved for future applications.

12. RS-232 ports

6-pin modular RJ-11 jacks provide serial control. Two connectors labeled Port 1 (reserved for internal use) and Port 2 (used for RS-232 control) are provided.

13. trigger input connector

One 1/8-inch (3.5mm) mini-jack labeled trigger input is available to receive trigger signals. The mini-jack requires a mini-plug (Tip/Sleeve) connection.

14. IR input connector

Accepts 12V infrared input signals with no more than 100mA of current from standard infrared distribution equipment such as IR repeaters. One 1/8-inch (3.5mm) mini-jack labeled IR input is available. The mini-jack requires a mini-plug (Tip/Sleeve) connection in which the tip of the mini-plug has positive polarity.

15. region code indicator

Indicates the N°51 region code, which differs depending on the region of purchase. All DVD-Vs are marked with a region code, which is often located on the disc packaging. The N°51 is compatible with discs marked with the same region code as the region code on the back of the player. The N°51 is not compatible with discs marked with other region codes.

Remote Control

The N°51 remote control provides full operation of the N°51. It requires special consideration during operation to ensure optimal performance. Pay particular attention to instructions included in this section and to precautions included throughout this owner's manual.

The right side of the front-panel display includes an IR receiver that receives infrared commands from the remote control IR transmitter when the N°51 is not using the IR input connector.

Note

The items below are not applicable when the N°51 is using the IR input connector.

When operating the remote control:

DO eliminate obstructions between the remote control IR transmitter and the front-panel display IR receiver.

DO position the remote control within $\pm 45^\circ$ of a line that is perpendicular to the front-panel display IR receiver. At more severe angles, attempt to "bounce" the remote control signal off a wall or another surface so the signal is received at the IR receiver at a reasonable angle.

2-9

DO position the remote control within 17 feet (5m) of the front-panel display IR receiver. If the N°51 is placed inside a glass cabinet, tinted glass will reduce the remote control range.

DO replace the remote control batteries as needed. In some cases, the remote control IR transmitter LED will light more dimly (or not at all) if the remote control batteries need to be replaced. See "Remote Control Batteries" on page 1-10 for instructions.

DO NOT obstruct the front-panel display IR receiver, which must be in line-of-sight with the remote control IR transmitter for proper remote control operation.

DO NOT expose the front-panel display IR receiver to strong sunlight, halogen light, or fluorescent light. This can cause IR reception to become unreliable.

DO NOT use remote controls for different components at the same time. Remote controls for different components can interfere with one another.

Remote Control Functions

Figure 2-7: Remote control functions

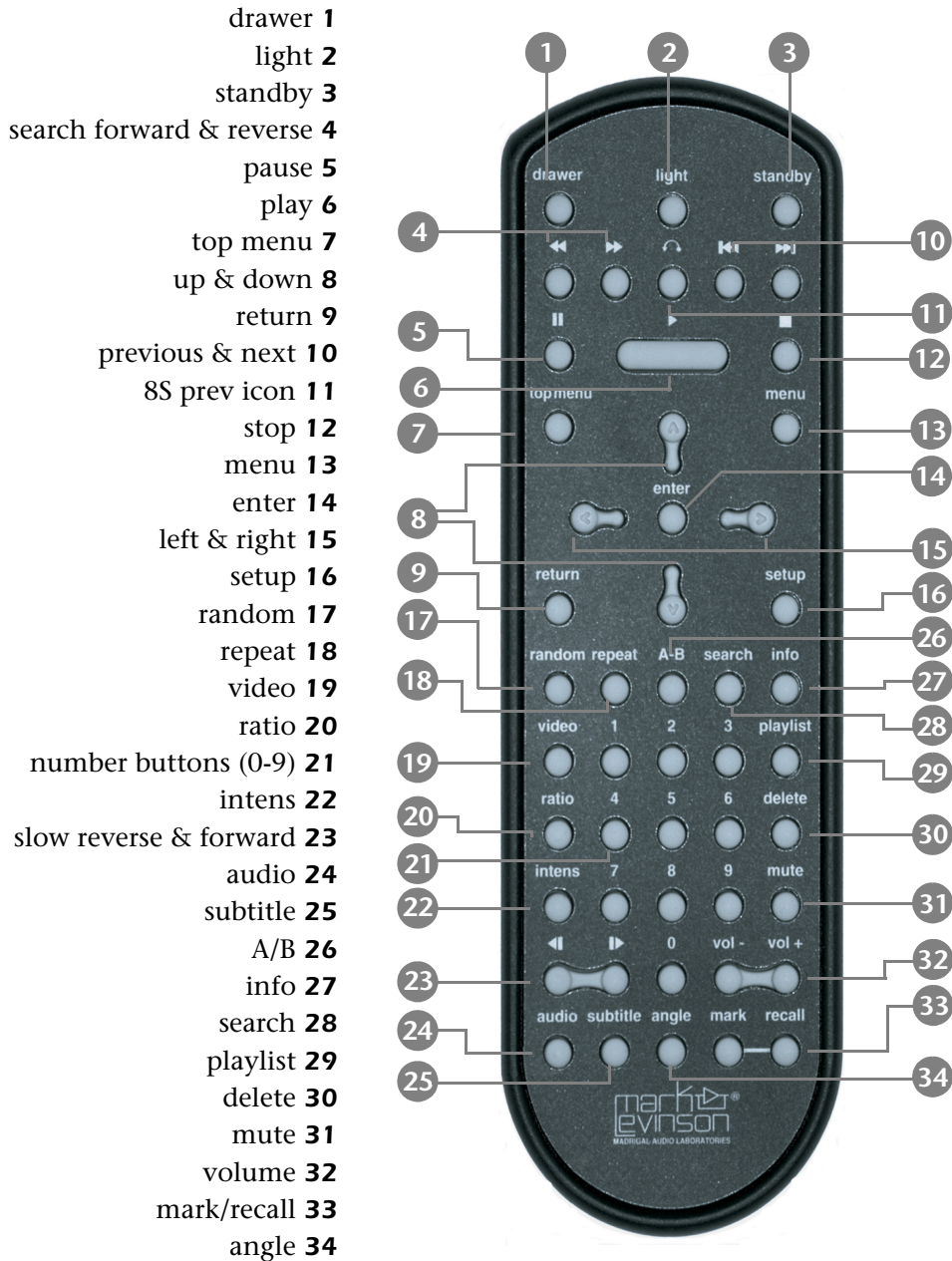

2-10

Below is a description of each item listed above.

- 1. drawer** Opens and closes the disc drawer. The drawer button can also be used to take the player out of standby mode, or to remember the current playback location by setting an automatic bookmark when ejecting the disc. For more information, see “Manual and Automatic Bookmarks” on page 4-17.

- 2. light** Turns on the remote-control backlight. After seven seconds the backlight automatically shuts off.
- 3. standby** Places the media player into or out of standby mode. When in standby mode, the media player is placed in a low power mode that conserves energy.
- 4. search forward & reverse** When the media player is playing, pressing the forward or reverse (◀/▶) button starts a reverse or forward search of the disc. Repeatedly pressing the buttons toggles through the available search speeds: 2x, 4x, 8x and 16x. When forward or reverse is activated, an indicator appears in the on-screen display. For more information, see “Fast Search (fwd/rev)” on page 4-8.
- 5. pause** Pressing the pause button (⏸) pauses playback at the current position. When playing a DVD, pausing playback allows viewing of a single frame.
- When DVD playback is paused, pressing and releasing the remote control forward (▶) button starts frame-by-frame playback in the forward direction. For more information, see “Frame-by-frame” on page 4-9.
- When pause is activated, an indicator appears in the on-screen display. For more information, see “Pause” on page 4-7.
- 6. play** Closes the drawer if the drawer is open; or starts playback:
- From beginning of a disc if just loaded, or from the last playback position if **stop** (■) was pressed.
 - At current position if **pause** (⏸) was pressed.
 - From standby mode.
- When play is activated, an indicator appears in the on-screen display. For more information, see “Play” on page 4-6.
- 7. top menu** Pressing the **top menu** button displays the top level disc menu. The content of the menu is dependent upon the disc format. If the top menu of a DVD is playing and the top menu button is pressed, the DVD resumes playback at the last position. For more information, see “Disc Menu Navigation” on page 4-2.
- 8. up & down** When a menu is open, pressing the up or down button scrolls upward or downward through the currently displayed list. Pressing and holding the up or down button scrolls upward or downward through the list until the button is released. If the end of the Setup menu is reached the cursor stops. For more information, see “Disc Menu Navigation” on page 4-2.

9. return Backtracks through the Setup menu hierarchy level-by-level. Unsaved changes are not saved. When a DVD menu is displayed, pressing return initiates or resumes playback. For more information, see “Setup Menu Navigation” on page 3-1 and “Disc Menu Navigation” on page 4-2.

10. previous & next During playback, pressing the previous or next button (◀ / ▶) starts playback from the beginning of the current chapter/track or skips forward to the next chapter or track.

If the player is in Pause mode, the player skips to the specific chapter or track but remains in Pause mode until the play button is pressed.

11. 8S prev Jumps the playback position back 8 seconds and continues playback from that point. When 8S prev is activated, an indicator appears in the OSD. For more information, see “8s prev” on page 4-9.

12. stop Press the stop button (■) to stop playback. Some DVDs require pressing the stop button twice to stop playback. When Stop mode is activated, an indicator appears in the on-screen display. For more information, see “Stop” on page 4-7.

2-12

13. menu Opens or exits the disc’s on-screen menu. When playing a DVD, pressing the menu button after configuring a disc menu resumes playback at the last position. When playing a CD, pressing the menu button displays the track list. For more information, see “Disc Menu Navigation” on page 4-2.

14. enter Used in conjunction with the 4-way button (up, down, left, and right). When a disc menu is open, pressing the **enter** button confirms selection of the highlighted menu item. In some cases, pressing enter initiates playback. For more information, see “Disc Menu Navigation” on page 4-2.

15. left & right When a disc menu is open, pressing the **left** or **right** (◀ / ▶) button changes the value of the currently selected menu item, or moves the cursor left or right in the menu. For more information, see “Disc Menu Navigation” on page 4-2.

16. setup Opens and closes the Setup menu in the on-screen display, allowing you to access menu functions. For more information, see “Disc Menu Navigation” on page 4-2.

- 17. random** Switches between different random modes for the currently playing disc. Available modes are dependent upon the disc type. For more information, see “Random” on page 4-11.
- 18. repeat** Switches between different repeat modes for the currently playing disc. Available modes are dependent upon the disc type. For more information, see “Repeat” on page 4-12.
- 19. video** Switches video output on and off.
- 20. ratio** Switches video zoom ratios between Normal, Widescreen, Fill and Fill + Wide. For more information, see “zoom ratio” on page 4-5.
- 21. number buttons (0-9)** Activates playback at a specific location on the disc.
- When a disc is loaded and the disc menu is closed, pressing a number button activates playback at the selected title, chapter or track number.
 - To enter values 10 and above, press the first digit button and within 3 seconds press the second digit. For instance, entering a value of **14** requires a button sequence of **1** and **4**.
 - To enter values for 1 to 9, press the digit and then press the **enter** button or wait 3 seconds.
- For more information, see “Disc Menu Navigation” on page 4-2.
- 22. intens** Cycles through the front-panel display intensity levels, allowing adjustment for varying ambient lighting conditions. Available intensity levels include 25%, 50%, 75%, 100% and Off. When “Off” is selected, the display lights for a few seconds whenever a setting is changed.
- 23. slow forward & slow reverse**
- When the media player is paused, playing at normal speed, or in slow reverse, pressing the slow button scans forward through the loaded disc in slow speed.
- When the media player is paused, playing at normal speed, or in slow forward, pressing the slow reverse (◀) button scans through the loaded disc in reverse direction at 2x speed.
- Repeatedly pressing the slow forward (▶) button increases the scan speed through the following speeds: 1/16x, 1/8x, 1/4x and 1/2x.
- When slow forward or slow reverse is pressed, an indicator appears in the on-screen display. For more information, see “Slow Search (slow fwd/rev)” on page 4-8.

- 24. audio** Switches between available audio tracks, language and formats on the loaded disc. For more information, see “audio” on page 4-3.
- 25. subtitle** Switches between available subtitle languages on the loaded disc. For more information, see “subtitle language” on page 4-3.
- 26. A-B** Repeats playback from a user-defined start point (A) to a user-defined end point (B). For more information, see “A-B Repeat” on page 4-13.
- 27. info** Displays or hides status information for the current disc. For more information, see “Info Mode” on page 4-19.
- 28. search** Activates search mode, which activates playback of a specific title, chapter, track or time on the loaded disc. Available search modes are disc format dependent. For more information, see “Search” on page 4-10.
- 29. playlist** Opens and closes the playlist menu, which is used to create a playlist for the current CD. Playlists can be created and stored for up to 1000 discs. For more information, see “Playlist” on page 4-14.
- 2-14 **30. delete** Deletes inserted numbers in search mode, tracks in playlist mode, entered codes during system checks, and resets numbers during numerical input. For more information, see “Disc Menu Navigation” on page 4-2.
- 31. mute** Attenuates the analog audio output level by a user-defined amount or fully mutes analog audio output. Digital audio output is not affected. Output levels range from -10 to -40 decibels in 10 decibel increments and Full Mute. For more information, see “Volume Control” on page 3-11.
- 32. volume ±** Adjusts volume level when the Volume parameter is set to “Variable”. Use the volume ± rocker buttons increases and decreases the volume level. These buttons have no effect when the Volume parameter is set to “Fixed.” For more information, see “Volume Control” on page 3-11.
- 33. mark/recall** During DVD-V playback, pressing **mark** creates a bookmark at the current playback position. Bookmarks can be stored for up to 1000 discs. During playback, pressing **recall** jumps playback to the stored bookmark for the current disc. For more information, see “Manual and Automatic Bookmarks” on page 4-17.
- 34. angle** When a DVD is playing, pressing **angle** switches between available camera angles on the loaded disc. When **angle** is active, a camera angle icon is displayed in the on-screen display. For more information, see “camera angle” on page 4-4.

3

Setup Menu

Setup Menu

The front-panel or remote-control **setup** button provides convenient access to the Setup menu, which is used to configure Audio, Video, Disc and General media player settings to suit individual preferences.

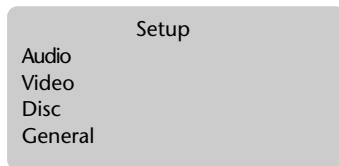

To open the Setup menu:

Press the remote control or front-panel **setup** button. The Setup menu opens in the on-screen display.

There are four menu entries on the left side of the Setup menu window—**Audio**, **Video**, **Disc** and **General**. When a submenu is selected, a preview of associated settings is displayed on the right side of the window.

- **Audio** options control audio output.
- **Video** options control video output formats and settings.
- **Disc** options control language, bookmarks and camera angle settings.
- **General** options control screen saver and factory-default settings.

3-1

Setup Menu Navigation

To navigate through the Setup menu, use the remote control or front-panel **4-way** (up, down, left and right), **enter** and **setup** buttons.

Button	Command
enter	• Selects the highlighted option or parameter.
return	• Closes the current menu without saving selected settings, and opens the previous menu.
up & down	• Scrolls upward or downward through the current list of menu items.
left & right	• Moves the cursor left or right in the current menu. • Adjusts the selected setting by increasing or decreasing the setting in the designated increment.
setup	• Opens and closes the Setup menu.

Setup Menu Navigation (continued)**To select a menu item:**

1. Press the remote control or front-panel **setup** button.
2. Using the remote control **up** or **down** button, highlight the desired menu item. The highlighted item appears in a larger font size.
3. When the desired menu item is highlighted, press the **enter** button to select the highlighted item.
 - If a menu option is selected, another menu will open. For example, selecting the **audio** option from the Setup menu, opens the Audio menu.
 - Parameters utilizing a horizontal *slider* indicate the parameter's current position within the entire parameter range.

To adjust a parameter using a slider:

1. When the slider appears, press the remote control **left** or **right** buttons to decrease or increase the parameter setting in the designated increments.
2. When the desired adjustments have been made, press the remote control **enter** or **return** button to close the slider.

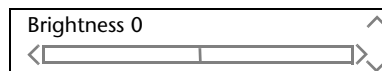

3. Repeatedly press the **return** button to back out of the menu structure, or press the **setup** button to close the menu structure.

Audio Setup

This section includes all parameters that control audio output. To access audio parameters, select **Audio** from the Setup menu.

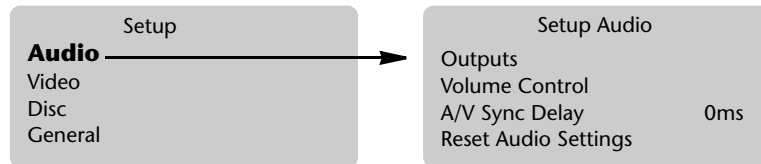

Outputs: HDMI Audio Preferences

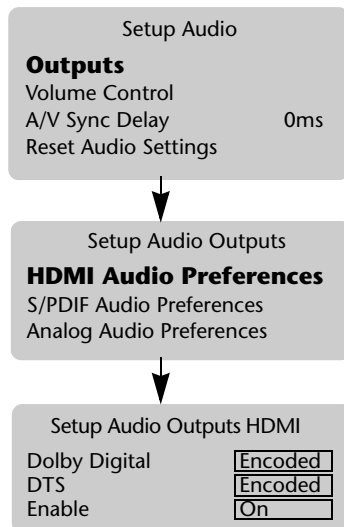

Use the HDMI Audio Preferences option to set the output behavior of an audio source when the N°51 Media Player is using the HDMI connector, and the video output switch is set to HDMI.

Parameter	Default	Possible Settings
Dolby Digital	Encoded	Encoded, PCM
DTS	Encoded	Encoded, PCM
Enable	On	On, Off

Dolby Digital (Setup : Audio : Outputs : HDMI Audio Preferences: Dolby Digital)

Use the Dolby Digital option to set the output behavior of a Dolby Digital-encoded source when the media player is using the HDMI connector. An HDMI device will automatically communicate the number of channels it has the ability to accept.

To select an audio format:

Using the remote control **up** or **down** button, highlight the desired setting, and press **enter**.

- Select **Encoded** if the associated component is compatible with Dolby Digital-encoded sources. The N°51 Media Player will pass Dolby Digital signals directly to the associated component.
- Select **PCM** if the associated component is not compatible with Dolby Digital encoded sources. The N°51 Media Player will downmix Dolby Digital signals to 2-channel PCM before being sent to the HDMI output.

Outputs: HDMI Audio Preferences *(continued)*

DTS (Setup : Audio : Outputs : HDMI Audio Preferences : DTS)

Use the DTS option to set the output behavior of a DTS-encoded source when the N°51 Media Player is using the HDMI connector.

To select an audio format:

Using the remote control **up** or **down** button, highlight the desired setting, and press **enter**.

- Select **Encoded** if the associated component is compatible with DTS-encoded sources. The N°51 Media Player will pass DTS signals directly to the associated component.
- Select **PCM** if the associated component cannot accept a DTS-encoded audio format. The N°51 Media Player will downmix DTS signals to 2-channel PCM.

Enable (Setup : Audio : Outputs : HDMI Audio Preferences : Enable)

Use the **Enable** option to enable or disable the audio portion of the rear-panel HDMI output port in the software.

When set to **On**, the three-position video output switch (rear panel) must be set to HDMI to enable HDMI audio.

When set to **Off**, the audio portion of the HDMI output port is disabled in the software even if the three-position video output switch is set to HDMI. HDMI video output is not affected. If set to Off, use the digital audio outputs or the analog audio outputs.

Outputs: S/PDIF Audio Preferences

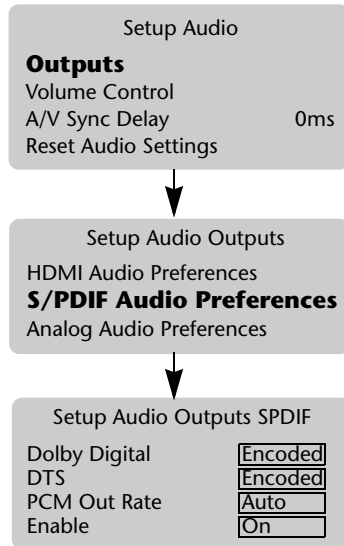

Use the S/PDIF Audio Preferences option to set the audio behavior of a digital audio source when the Nº51 Media Player is using a digital audio output connector (AES/EBU, S/PDIF or EIAJ). These parameters have no effect when using any of the analog output connectors.

Audio Source	Default	Possible Settings
Dolby Digital	Encoded	Encoded, PCM
DTS	Encoded	Encoded, PCM
PCM Out Rate	Auto	Auto, 44.1, 48, 88.2, 96kHz
Enable	On	On, Off

Dolby Digital (Setup : Audio : Outputs : S/PDIF Audio Preferences : Dolby Digital)

Use the Dolby Digital option to set the output behavior of a Dolby Digital-encoded source when the media player is using a digital audio output connector.

To select an audio format:

Using the remote control **up** or **down** button, highlight the desired setting and press **enter**.

- Select **Encoded** if the associated component is compatible with Dolby Digital sources. The Nº51 Media Player will pass Dolby Digital-encoded signals directly to the associated component.
- Select **PCM** if the associated component is not compatible with Dolby Digital sources. The Nº51 Media Player will downmix Dolby Digital-encoded signals to 2-channel PCM before passing them to the associated component.

DTS (Setup : Audio : Outputs : S/PDIF Audio Preferences : DTS)

Use DTS option to set the behavior of DTS source when the Nº51 Media Player is using a digital audio output connector.

To select an audio format:

Using the remote control **up** or **down** button, highlight the desired setting and press **enter**.

- Select **Encoded** if the associated component is compatible with DTS sources. The Nº51 Media Player will pass DTS signals directly to the associated component.

Outputs: S/PDIF Audio Preferences (continued)

WARNING: If the DTS parameter is set to Encoded and the associated component is not compatible with DTS sources, it will output noise when a DTS source is present. In this case, set the DTS parameter to PCM.

- Select **PCM** if the associated component is not compatible with DTS sources. The N°51 Media Player will downmix DTS encoded sources to 2-channel PCM before passing them to the associated component.

PCM Out Rate (Setup : Audio : Outputs : S/PDIF Audio Preferences : PCM Out Rate)

Use the PCM Out Rate to adjust the PCM output rate of the N°51 Media Player. Check the owner's manual of the associated component for sampling rate compatibility.

To select an output rate:

Using the remote control **up** or **down** button, highlight the desired setting and press **enter**.

When Auto is selected, the N°51 Media Player uses the native sample rate on the source disc.

Enable (Setup : Audio : Outputs : S/PDIF Audio Preferences: Enable)

Use the **Enable** option to enable or disable the digital audio output ports (AES/EBU, S/PDIF and EIAJ) in the software.

Outputs: Analog Audio Preferences

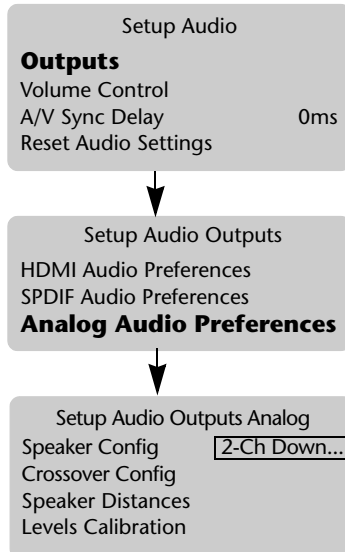

Speaker Configuration (Setup : Audio : Outputs : Analog Audio Preferences : Speaker Configuration)

Use the **5.1** option to configure the Nº51 Media Player to pass multi-channel audio sources to the analog audio output connectors labeled **6 Channel Analog Outputs**.

Use the **2-Ch Downmix** option to configure the Nº51 Media Player to downmix all multichannel audio sources to 2-channel before passing them to the analog outputs.

- Two-channel and 2-channel downmixed audio streams are output from the XLR and RCA analog output connectors as well as the **6 Channel Analog Outputs connectors** labeled **R** (right front) and **L** (left front).
- The Crossover Configuration option is not available when using the 2-Ch Downmix parameter and appears grayed-out in the menu.

Crossover Configuration (Setup : Audio : Outputs : Analog Audio Preferences : Crossover Configuration)

Crossover Configuration is used to assign independent crossover points for each of the 6-channel audio output connectors. The table below indicates default and possible crossover ranges for each speaker parameter.

3-7

Parameter	Default		Possible Settings
	5.1	2-Ch	
Front L/R	80 Hz	Full	Full, 30 to 120 Hz; in 10Hz steps
Center		None	Full, 30 to 120 Hz; in 10Hz steps, None
Surround L/R			Full, 30 to 120 Hz; in 10Hz steps, None
Subwoofer			Full, 30 to 120 Hz; in 10Hz steps, None

- Low frequencies are redirected from speakers with the highest crossover points to speakers with the lowest crossover points.
- Low-frequency signals lower than the lowest crossover point are redirected to the subwoofer.
- If the Subwoofer is set to None, LFE information is redirected to the speakers with the lowest crossover setting.
- If the lowest crossover point is set to FULL, only LFE information is redirected to the subwoofer.
- If Center is set to None, dialogue shifts to Front L/R.

Outputs: Analog Audio Preferences *(continued)*

To assign crossover points:

1. Select **Crossover Config** from the Setup : Audio : Outputs : Analog Audio Preferences menu.
2. Using the remote control **up** or **down** button, highlight the desired speaker parameter and press **enter** to accept the selection.
3. Using the remote control **up** or **down** button, select the crossover point closest to the low-frequency rating of the associated speaker and press **enter**.
4. Press **return** to close the list and return to the previous menu, or press the **up** or **down** button to select a different speaker for configuration.

Speaker Distances (Setup : Audio : Outputs : Analog Audio Preferences : Speaker Distances)

Speaker Distances is used to configure the distance from each speaker to the primary listening position.

Note that audio streams are output from the XLR and RCA analog outputs as well as the 6 Channel Analog Outputs connectors labeled R (right front) and L (left front).

The table below indicates default and possible distances for each speaker parameter.

Parameter	Default	Possible Settings
Front Left	0.0 feet 0.0 meters	0 to 30 feet; in 0.5 steps 0 to 12 meters; in 0.2 steps
Center		
Front Right		
Surround Right		
Surround Left		
Subwoofer		
Units	Feet	Feet, Meters

To determine and set the appropriate distance for each speaker:

1. Measure the distance from the primary listening position to the front baffle of each speaker.
2. Select **Speaker Distances** from the Setup : Audio : Outputs : Analog Audio Preferences menu.

3. Using the remote control **up** or **down** button, highlight the desired speaker parameter and press **enter**.
A slider opens in the on-screen display.
4. Using the remote control **left** or **right** buttons, set the associated speaker parameter slider to the closest setting and press **enter**.
5. Press **return** to close the slider and return to the previous menu, or press the **up** or **down** button to select a different speaker.

Levels Calibration (Setup : Audio : Outputs : Analog Audio Preferences : Levels Calibration)

Levels Calibration is used to calibrate output trim levels for each speaker when the Volume parameter is set to "Variable." The table below indicates default and possible calibration settings for each speaker parameter. These parameters are not available when the Volume parameter is set to "Fixed".

Parameter	Default	Possible Settings
Front Left	0.0dB	-18 to +10dB; in 0.1dB steps
Center		
Front Right		
Surround Right		
Surround Left		
Subwoofer		

3-9

Before calibrating output levels, consider the following:

- Using a Sound Pressure Level (SPL) meter to calibrate variable output levels is recommended. An SPL meter is a device that measures the relative loudness of each speaker. SPL meters are available at Radio Shack.
- Eliminate extraneous noises in the listening space such as conversations, air conditioners, and sounds that filter in through open doors and windows.
- Remove objects (including people) that obstruct the line-of-sight path between the SPL meter and the speaker being measured.
- To be consistent, calibrate output levels from the primary listening position by placing the SPL meter at the approximate location of the listener's head.

Outputs: Analog Audio Preferences (continued)**To set output trim levels:**

1. Select the **Levels Calibration** option from the Setup : Audio : Outputs : Analog Audio Preferences menu. The **!CAUTION! HIGH AUDIO LEVELS** message opens to indicate the calibration procedure produces loud calibration test signals.
2. When this message appears, highlight **OK** and press **enter** to accept the selection and begin the calibration test.
 - When the calibration test is conducted, a test signal is sent to the 5.1 audio output connectors in the order listed in the menu.
 - If using a Radio Shack meter, set the SPL meter to “C” weighting and “SLOW” response.
3. Using the remote control **up** or **down** button, highlight the desired speaker parameter then press **enter** to select the parameter.
A slider opens in the on-screen display.
4. Using the remote control **left** or **right** buttons, adjust the parameter then press **enter** to accept the selection. All output levels should be adjusted to achieve a 75dB SPL meter reading from the primary listening position.
5. Press **return** to close the slider and return to the previous menu, or press the **up** or **down** button to select another speaker.

3-10

Note: When all sliders are at or below 0.0dB, a volume of 69.2 will correspond to the calibrated reference level. If any slider is adjusted in the positive direction (anywhere from 0.1 dB to 10.0dB), you must increase the volume by the amount of the highest positive slider value to achieve reference level.

For example:

Max Positive Slider	Volume for Calibrated Ref. Level
0 (or below)	69.2
+3.0dB	72.2
+5.5dB	74.7
+10dB	79.2

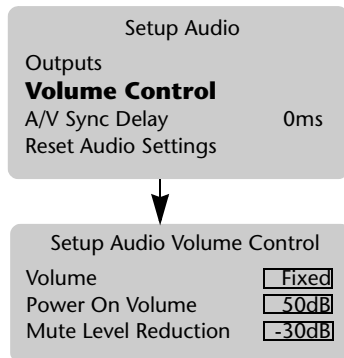

Volume Control

Use the **Volume Control** option to configure volume levels.

Parameter	Default	Possible Settings
Volume	Fixed	Fixed, Variable
Power On Volume*	50dB	30 to 70dB; in 10dB steps, Last Level
Mute Level Reduction	-30dB	-10 to -40dB; in 10dB steps, Full Mute

* Available in Variable mode only.

Volume (Setup : Audio : Volume Control : Volume)

Volume is used to configure the default volume to Fixed or Variable.

To set the default volume:

Using the remote control **up** or **down** button, highlight the desired setting and press **enter**.

- When the Volume parameter is set to Fixed, the Power On Volume parameter is not available and appears grayed-out. The default fixed value is 69.2dB or 2V (RCA) / 4V (XLR) output when playing a 0dBFS signal.
- Use Fixed when the media player is connected to a pre-amplifier or surround processor.
- When set to Variable, the N°51 Media Player remote control volume button controls the audio level. Use variable mode when connected directly to power amplifiers.
- When set to Variable, the N°51 Media Player allows precise steps of .1dB over the range of 20 to 80 and 1dB steps from 0 to 20.
- Adjusting the volume above 69.2 will result in extra gain above line level. This is often useful when connected to a power amplifier, but may cause clipping when connected to a pre-amplifier or surround processor.
- If any slider is adjusted in the positive direction during levels calibration, the volume setting required to attain calibrated reference level (normally 69.2) must be increased by the value of the max. positive slider (see Note on page 3-10).

Power On Volume (Setup : Audio : Volume Control : Power On Volume)

Power On Volume sets the volume level to the selected value when the N°51 Media Player is powered-on.

To set the Power On Volume:

Using the remote control **up** or **down** button, highlight the desired setting and press **enter**.

- When Last Level is selected, the N°51 Media Player automatically sets the volume level to the last volume level used during the previous operating session.
- When the Volume parameter is set to **Fixed**, the Power On Volume parameter is not available and appears grayed-out.

Mute Level Reduction (Setup : Audio : Volume Control : Mute Level Reduction)

Mute Level Reduction allows you to customize the amount of attenuation that occurs when the Mute button is pressed. The factory default setting is -30dB. You can select a value between -10 to -40dB in 10dB increments or Full Mute.

To set the Mute Level Reduction:

Using the remote control **up** or **down** button, highlight the desired setting and press **enter**.

- When **Full Mute** is selected, the volume level is fully attenuated when the Mute button is pressed.

3-12

A/V Sync Delay

Use the A/V Sync Delay option to synchronize the audio with the video. With some video processing systems, a delay between the audio and video may occur.

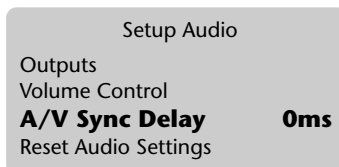

Parameter	Default	Possible Settings
A/V Sync Delay	0	0-110 ms

To set A/V Sync Delay:

Using the remote control **left** or **right** buttons, decrease or increase the parameter setting until the audio and video are in sync.

Note The A/V Sync Delay parameter applies to the analog audio outputs (2-Ch and 5.1 channel outputs), and also to any digital output (S/PDIF or HDMI) that is set to PCM. The A/V Sync Delay parameter does not have any effect on digital outputs (S/PDIF or HDMI) that is set to Encoded, since DRC is a function of the audio decoder (the surround processor that receives the encoded data stream from the N°51 Media Player).

Reset Audio Settings

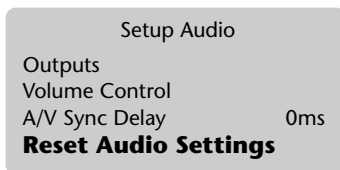

Use the **Reset Audio Settings** option to reset all audio settings in the Audio setup menu to their original settings.

Parameter	Default	Possible Settings
Reset Audio Settings	Yes	Yes, No

To reset audio settings:

Using the remote control **left** or **right** button, highlight the desired setting and press **enter**. It takes approximately 20 seconds until the original settings are restored.

Video Setup

Video parameters control video output formats and settings. To access video parameters, select **Video** from the Setup menu.

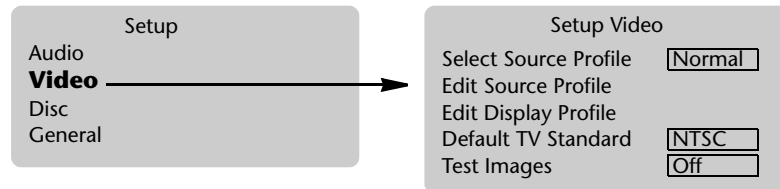

All DVDs played by the N°51 Media Player are MPEG encoded in SD (Standard Definition) format. The N°51 Media Player is capable of providing the video output from these discs in a variety of formats. Moreover, the N°51 Media Player is equipped with a high-quality video deinterlacer, scaler, and video processor, which further enhance the quality of the original SD source images and provide the best viewing experience.

Video Output Switch

Video formats are described in terms of their resolution, and separately their physical interface. To simplify the use and operation of the N°51 Media Player, the possible combinations of output video resolutions and their physical interfaces are controlled by a video output switch on the back panel of the N°51 Media Player.

The three-position video output switch selects between:

- **SD video** (top position) – Analog (Composite/S-Video) and Component SD Interlaced.
- **ED video** (middle position) – Component Progressive EDTV.
- **HDMI** (bottom position) – Digital HDMI.

The following table lists all possible video resolutions and interfaces for each video switch position.

Resolution or Format	Interlaced or Progressive	Frame Rate / Hz	CVBS [RCA]	S-Video	Component [BNC]	HDMI
720 x 480	I	30	SD video (NTSC)	SD video (NTSC)	SD video	HDMI*
720 x 576	I	25	SD video (PAL)	SD video (PAL)	SD video	HDMI*
720 x 480	P	60	X	X	ED video	HDMI*
720 x 576	P	50	X	X	ED video	HDMI*
1280 x 720	P	60	X	X	X	HDMI*
1280 x 720	P	50	X	X	X	HDMI*
1920 x 1080	I	30	X	X	X	HDMI*
1920 x 1080	I	25	X	X	X	HDMI*

* These outputs are provided at the resolutions supported over HDMI by the associated device.



Digital HDMI

The highest resolution that produces the cleanest and sharpest images over an all-digital interface is achieved via the HDMI output port. HDMI is a digital interface as well as a mode for the N°51 Media Player. To use HDMI mode, the associated display must have an HDMI input port. When using the N°51 Media Player with an HDMI-equipped display, use a high-quality HDMI cable. For very long runs, use an HDMI cable extender. You can also use the HDMI output port if the display supports DVI-D; use the appropriate adapters and cables, and follow the manufacturer's directions.

With the video output switch in the default **HDMI** position, the N°51 Media Player's high-quality deinterlacer, scaler and video processor produce stunning HD digital video. If your display supports the all-digital HDMI format, this is the preferred mode for watching all DVDs. User controls provide added flexibility for fine-tuning video processing functions, such as selecting a Film mode when watching a motion-picture DVD, or adding more enhancement or sharpness to the image.

There are several operational features of HDMI.

- An electronic EDID (**E**xtended **D**isplay **I**dentification **D**ata) connected to the HDMI output port, via the associated device, allows the N°51 Media Player to automatically detect supported video resolutions. The desired resolution can then be selected from the supported resolutions for display.
- The HDMI output port is functional with HDCP compliant devices only when the associated HDCP-equipped device detects the N°51 Media Player as a legal source of high-quality digital video.
- HDMI supports all HD resolutions. However, not all displays support all resolutions over the HDMI. Only those resolutions supported by the display can be selected for output by the N°51 Media Player.

3-15



Component Progressive EDTV

Component analog video is comprised of a luminance signal (Y), and two color-difference signals (Pb and Pr). If the display supports EDTV (Extended Definition Television) of 480p or 576p, you can choose to use the N°51 Media Player's Component Progressive EDTV mode by placing the video output switch (rear-panel) in the **ED video** (middle) position.

Component Video is an analog video format, and will not produce the clarity that can be achieved using the all-digital HDMI interface. However, Component Video (especially 480p or 576p) is superior to Composite or S-Video.

Analog and Component SD Interlaced



Analog standard definition video has a resolution of 480i or 576i, and is available on the Composite Video, S-Video, or Component Video (YPbPr) output ports. SD interlaced video can be used for monitoring the video signal output, or for other applications where high definition or progressive scan resolution is not required. To select the analog standard definition output, place the video output switch in the **SD video** (top) position.

When using the SCART interface, select the video to be output as Composite Video (CVBS), S-Video, or RGB video using the video output switch.

Select Source Profile

(Setup : Video : Select Source Profile)

Use the Select Source Profile option to activate a source profile. A Source Profile is a set of predefined parameters for each video mode. Source profiles are available for Normal, Film, Video/TV, Photo and Custom modes.

Parameter	Default	Possible Settings
Select Source Profile	Normal	Normal, Film, Video/TV, Photo and Custom

3-16

Edit Source Profile

(Setup : Video : Edit Source Profile)

Use the Edit Source Profile option to adjust the profile parameters of a source profile. The table below lists each available parameter, its function and possible settings.

Parameter	Function	Possible Settings
Brightness	Controls the lightness or overall tone of the image.	- 32 to 31; in 1.0 steps
Contrast	Controls the variations between the lightest and darkest areas in the image.	- 15 to 0; in 1.0 steps
Color Tint	Controls the red-to-green color balance of the image.	- 8 to 7; in 1.0 steps
Saturation	Controls the color intensity, or vividness of the image.	- 8 to 7; in 1.0 steps
Film Mode	Controls the detection of film cadence. For more information, see "Film Mode" on page 3-17.	On 2-2, On 3-2, On 2-2+3-2, Automatic, Off
Deinterlacing	Sets the deinterlacing method. For more information, see "Deinterlacing" on page 3-18	Bob, Weave, Adaptive, Compensat., Compensat.+
Compensat. + level	Sets the Compensat.+ threshold level. For more information, see "Deinterlacing" on page 3-18	7 to 0; in 1.0 steps
Noise Reduction	Controls the amount of noise reduction present in the video signals. For more information, see "Noise Reduction" on page 3-19	Off, On

Chroma Sharpness	Controls image sharpness using the color portion of the video signal. For more information, see “Chroma Sharpness” on page 3-19	Off, On
Luma Sharpness	Controls image sharpness using the luminance portion of the video signal. <ul style="list-style-type: none"> • Peaking • Transient Improvement For more information, see “Luma Sharpness” on page 3-19	0 to 9; in 1.0 steps 0 to 3; in 1.0 steps
Reset Source Profile	Resets the source profile to original settings.	Yes, No

Film Mode

In terms of source video material, there are two types of DVDs—video DVD and film DVD.

In video DVDs, the original source video is shot using a video camera with a frame rate of 60Hz interlaced for NTSC and 50Hz interlaced for PAL/SECAM. In film DVDs, the original source video is shot with a film camera, which is progressive scan and has a frame rate of 24Hz (i.e. 24p for NTSC), 25Hz (i.e. 25p for PAL) or 30Hz (i.e. 30p for NTSC).

These different source materials are encoded as MPEG2 video and stored digitally on DVDs, following the ITU-R BT.601 standard, which offers two possible output frame rates: the interlaced 60Hz (i.e. 480i@60Hz for NTSC) or the interlaced 50Hz (i.e. 576i@50Hz for PAL). To convert the source of 24p to 480i@60Hz, a telecine process known as 3-2 pulldown is applied—to create 10 video fields out of four film frames.

To achieve the optimized video quality, the N°51 offers different processing methods depending on the original source. You can use automatic mode, or force it to use a specific mode.

Parameter setting	Description
Automatic	In this mode, the N°51 automatically detects the source material.
Video	Forces the N°51 to run in video mode only. Use if you are watching a video DVD shot at interlaced 50Hz or interlaced 60Hz.
3-2	Forces the N°51 to run in 3-2 pulldown mode. Use 3-2 only if you are watching an NTSC film DVD at 24p (most NTSC film DVDs).
2-2	Forces the N°51 to run in 2-2 pulldown mode. Use if you are watching a PAL film DVD at 24p (most PAL film DVDs). This mode also works for a NTSC film DVD at 30p or a PAL film DVD at 25p (only some film DVDs).
2-2 and 3-2	In this mode, the N°51 automatically detects which type of film DVD you are watching.

Deinterlacing

Standard DVDs are normally encoded as either interlaced 60Hz (i.e. 480i@60Hz for NTSC) or interlaced 50Hz (i.e. 576i@50Hz for PAL). Interlaced video can display many annoying video artifacts, such as flickering, combing (referred to as “feathering”), etc. To lessen the video artifacts associated with interlaced video, the N°51 offers all the well-known deinterlacing categories. Briefly, deinterlacing is used to create 50 frames/sec. from 50 fields for PAL or 60 frames/sec. from 60 fields for NTSC in each second.

Parameter setting	Description
Bob	This method applies spatial interpolation to every field to create a whole frame. The advantage of this method is that there is no feathering artifact for moving objects. The two major unavoidable artifacts of this method are thin line flickering and loss of picture details due to interpolation. The N°51 applies an improved interpolation method to minimize the second artifact.
Weave	This method applies temporal interpolation of two consecutive fields, which are merged (“woven”) into one frame. It is suitable for still images with full resolution but results in saw edges and feathering effects on moving objects.
Motion Adaptive	This method applies the Bob method for moving objects and the weave method for still areas. In other words, for one created frame, some parts are generated from field interpolation, others are from weaving. This method can produce advantages from both the Bob and the Weave method.
Motion Compensat.	This is the most advanced method using state-of-the-art technology. For moving objects, in addition to interpolating the data from each field into frames, this method estimates the motion and applies both temporal and spatial interpolation methods. Compared to the motion adaptive method, Motion Compensat. achieves improved picture detail and a much smoother-looking picture is achieved.
Motion Compensat. +	Sometimes motion estimation using the motion compensation method can produce “Halo”-effects, which appear as contours around edges of moving objects. Motion Compensat.+ automatically switches between pure motion adaptive and pure motion compensation to always provide an optimized solution. In addition, the N°51 offers a threshold level adjustment to ensure optimum performance. Setting the threshold level to a lower number will make Motion Compensat.+ more like pure Motion Adaptive, while setting it to a higher number will make Motion Compensat.+ more like pure Motion Compensat.

Noise Reduction

This parameter applies a special filter to suppress cross-color artifacts, where high-frequency luma might improperly display as “false colors”. Noise Reduction should only be used if cross-color artifacts are obvious.

Luma Sharpness

This parameter applies Luma enhancement, which improves the sharpness of edges. The Peaking setting is used to linearly process the data, and is mostly suitable for small signal amplitudes. Transient Improvement, a non-linear method of processing, is more appropriate for improving sharpness and avoiding under- and over-shoots of peaking.

Chroma Sharpness

The Chroma Sharpness parameter applies chrominance enhancement, which improves the horizontal transitions of chrominance signals. Chroma Sharpness should only be used if blurred colors from source material are obvious.

Edit Display Profile: HDMI Out



HDMI output parameters control the video format when the N°51 Media Player is using the HDMI output connector, and the video output switch (on rear panel) is set to **HDMI**. When the video output switch is set to HDMI, all analog video outputs are disabled.

Parameter	Default	Possible Settings
Video Format*	YCbCr 4:2:2	RGB Normal, RGB Expand, YCbCr 4:2:2, YCbCr 4:4:4
Resolution*	PS	SD, PS, HD 720p, HD 1080i
Display Aspect Ratio	16:9	16:9, 4:3, 4:3 P&S
Zoom Ratio	Normal	Normal, Widescreen, Fill, Fill + Wide
Reset Display Profile	Yes	Yes, No

* Settings not supported by the currently connected HDMI display will be grayed-out and not available.

HDCP (**H**igh-bandwidth **D**igital **C**ontent **P**rotection) is designed to protect the integrity of content as it is being transmitted, and to prevent illegal copying of that content. When the N°51 Media Player is connected to a device through an HDMI cable and the video output switch is set to HDMI, the following occurs: Authentication is established between the N°51 Media Player and the other device and video is transmitted to that device. If authentication fails, video is not transmitted.

3-20

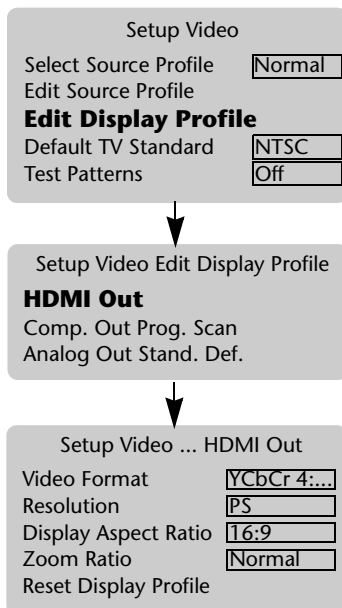

Video Format (Setup : Video : Edit Display Profile : HDMI Out : Video Format)

Video Format is used to set the video format of the source when the N°51 Media Player is using the HDMI output connector.

The HDMI output port produces the cleanest and sharpest images for your display. Select the HDMI video output format that best matches your system configuration and personal preferences. The following video pixel encoding options are available for the N°51 HDMI video output:

- RGB Normal
- RGB Expand
- YCbCr 4:2:2
- YCbCr 4:4:4

To select a video format:

First, decide between digital RGB video and digital Component video (YCbCr). Choose RGB video to take advantage of the high-quality 4:2:2 to 4:4:4 chrominance interpolation and color space conversion matrix within the N°51. If you wish to utilize the color

space conversion matrix within your display or external video processor, select YCbCr.

If you decide to use the RGB format, choose between RGB Normal and RGB Expand.

- Image data values in the RGB Normal format provide a black level at 16 and have some headroom at peak white to allow for small overshoots and undershoots.
- Image data values in the RGB Expand format provide a black level at 0 and a higher dynamic range for peak white.

If you decide to use the YCbCr digital Component video format, choose between YCbCr 4:2:2 and YCbCr 4:4:4.

- YCbCr 4:2:2 utilizes the chrominance interpolation and color space conversion matrix within your display or sink device.
- YCbCr 4:4:4 utilizes the color space conversion matrix within your display or sink device.

Note:

RGB Normal and RGB Expand can be selected for DVI output interconnections between your N°51 and your display or sink device.

3-21

Resolution (Setup : Video : Edit Display Profile : HDMI Out : Resolution)

The Resolution setting is used to control output resolution. The N°51 Media Player supports the following resolutions:

SD	Standard Definition 480/576 interlaced
PS	Progressive Scan 480/576 progressive
HD 720p	High Definition 720 progressive
HD 1080i	High Definition 1080 interlaced

To select a resolution:

Using the remote control **up** or **down** button, select the desired setting and press **enter**.

Available resolutions are dependent upon the capabilities of the associated display. When a display is connected, only resolutions that are supported by the display are available for selection. Resolutions that are not supported by the display appear as grayed-out in the selection list.

Edit Display Profile: HDMI Out *(continued)*

If a different display is connected and the new display does not support the previously used resolution, the next possible resolution selection will be automatically selected. If only one resolution is possible, the resolution will automatically be activated.

- **Standard Definition (SD)**

Interlaced video is a method for reducing the bandwidth of a video signal. To decrease the size of the signal, each video frame is split into two sequential fields, one containing the field's odd lines and the other containing the field's even lines. The frame rate is then equal to 1/2 the field rate. Standard Definition video (interlaced video) is susceptible to deinterlacing artifacts.

Standard Definition resolution uses less bandwidth, is typically a 480/576i (interlace) low resolution digital signal and displays at 30 frames per second (NTSC) or 25 frames per second (PAL).

- **Progressive Scan (PS)**

Progressive Scan (PS) indicates that the frame is not split into fields, but is sent as a single entity. Progressive Scan picture quality has more detail and less flicker than Standard Definition.

Progressive Scan displays at a resolution of 480p (progressive) at 60 frames per second for NTSC, and 50 frames per second for PAL.

- **HD 720p** displays a high definition 1,280 by 720p resolution.
- **HD 1080i** displays a high definition interlaced format with a resolution of 1,920 by 1080i.

3-22

Display Aspect Ratio (Setup : Video : Edit Display Profile : HDMI Out : Display Aspect Ratio)

Display Aspect Ratio is used to define the aspect ratio (width to height) used to display the source video.

For optimum performance, select the aspect ratio that matches the aspect ratio of the associated display. For example, a 64-inch wide by 36-inch high screen has a 16:9 aspect ratio and a diagonal screen dimension of nominally 73 inches.

DVDs come in various formats to accommodate different aspect ratios. You can optionally adjust the Zoom Ratio to eliminate black bars that may appear if the DVD and display aspect ratios do not match. Generally, the display aspect ratio setting is a one-time set-up, whereas Zoom Ratio settings for eliminating black bars may change based on viewing preferences and the particular format of the DVD.

The N°51 Media Player offers the following aspect ratios:

Display Aspect Ratio	
16:9	<ul style="list-style-type: none"> • Standard aspect ratio of a HDTV. • Closer to the aspect ratios used in theatrical movies. • Displays 4:3 content with black bars on the left and right of the screen (pillarboxing). • Select 16:9 when a 16:9 widescreen display is connected to the N°51 Media Player.
4:3	<ul style="list-style-type: none"> • Displays normal 4:3 content as full-frame with no black bars. • Displays widescreen content with black bars on the top and bottom of the screen (letterboxing). • Select 4:3 when a standard display or TV is connected to the N°51 Media Player.
4:3 P&S	<ul style="list-style-type: none"> • Auto Pan & Scan is a technique used on some DVD titles for fitting a widescreen image into the standard 4:3 display format. Selecting 4:3 P&S allows widescreen DVD titles that are encoded with Auto Pan & Scan vectors to zoom in to fill the screen, and automatically pan left and right to follow the most important action. • For widescreen DVDs that are encoded with Auto Pan & Scan vectors, the content will fill the screen and appear as 4:3 with no black bars. • For widescreen DVDs that do not support Auto Pan & Scan, the content will be displayed with black bars on the top and bottom of the screen (letterboxing). • Displays normal 4:3 content as full-frame with no black bars. • Select 4:3 P&S as an alternative to 4:3 when a standard display or TV is connected to the No51 Media Player. For titles that do not support Auto Pan & Scan, there will be no difference between 4:3 P&S and 4:3 settings.

3-23

To select a display aspect ratio:

Use the remote control **up** or **down** button to select the desired setting and press **enter**.

Note

For examples of how Display Aspect Ratio, DVD format and Resolution settings affect the display output, see “Display Aspect Ratio” on page A-8.

Zoom Ratio (Setup : Video : Edit Display Profile : HDMI Out : Zoom Ratio)

Zoom Ratio is used to adjust the aspect ratio of source content that does not match the aspect ratio of the display. Before adjusting the Zoom Ratio, be sure that the N°51 Media Player has been properly configured to match the aspect ratio of the associated display.

Edit Display Profile: HDMI Out (continued)

The N°51 Media Player offers the following zoom ratios:

Zoom Ratio	
Normal	<p>Select Normal when no zoom is desired. The video output from the N°51 to the display is based on the selected Display Aspect Ratio.</p> <ul style="list-style-type: none"> • For 16:9 displays: Widescreen (anamorphic) source content appears using the default aspect ratio on the DVD, and is displayed in a 16:9 aspect ratio. You can optionally zoom and remove the letterboxing caused by viewing a 2.35:1 widescreen (anamorphic) DVD (see <i>Widescreen</i> below). • For 4:3 displays: Widescreen (anamorphic) source content appears in Letterbox format; 4:3 full-frame content appears as full-frame; Pan & Scan content appears as full-frame if 4:3 P&S is selected as the Display Aspect Ratio. (To optionally remove the letterboxing, see <i>Fill</i> below).
Widescreen	<ul style="list-style-type: none"> • Select Widescreen for 16:9 displays only if the source material on the DVD is widescreen (anamorphic) with a 2.35:1 aspect ratio. • If Widescreen is selected, the black bars that otherwise appear at the top and bottom of a 16:9 display are removed for 2.35:1 DVD content by zooming into the picture. Zooming results in a slight cropping of the left and right sides of the image and a small amount of resolution loss due to image scaling; however, there are no geometric distortions and the source material appears without letterboxing.
Fill	<ul style="list-style-type: none"> • For 16:9 displays: Select Fill when viewing the content of a Full-frame (4:3) DVD on a 16:9 display. Black bars on the left and right of the display (pillarboxing), are eliminated by zooming the image and cropping it, top and bottom. Picture resolution is slightly reduced due to scaling; however, there is no geometric distortion, and the image fills the display screen. • For 4:3 displays: Select Fill when viewing the content of a Letterbox DVD on a 4:3 display. Black bars (on the top and bottom of the display) are reduced or eliminated by zooming the image and cropping the sides slightly. Picture resolution is slightly reduced due to scaling; however, there is no geometric distortion, and the image fills the display screen. The DVD will probably be labeled as widescreen (anamorphic). Note that if the source material on the DVD is in an aspect ratio other than 16:9, selecting Fill will not totally remove the letterboxing.
Fill + Wide	<ul style="list-style-type: none"> • Select Fill + Wide for the maximum amount of zoom. This is equivalent to having both Fill and Widescreen zoom modes active at the same time. • Use this mode only when playing a 2.35:1 widescreen DVD on a 4x3 display. This will completely eliminate black bars on the top and bottom of the screen.

Reset Display Profile (Setup : Video : Edit Display Profile : HDMI Out : Reset Display Profile)

Reset Display Profile resets the parameters of the display profile associated with the HDMI connector to the original settings.

To reset the display profile:

1. Use the remote control **up** or **down** button to select “Reset Display Profile” and press **enter**.
2. When prompted to confirm the selection, press **enter**.

**Edit Display Profile:
Comp. Out Prog. Scan**



Component Output Progressive Scan parameters control the video format when a PS (480/576p) source is present, the N°51 Media Player is using the Component video output connectors, and the video output switch (on rear panel) is set to **ED video**.

Parameter	Default	Possible Settings
Display Aspect Ratio	4:3	16:9, 4:3, 4:3 P&S
Zoom Ratio	Normal	Normal, Widescreen, Fill, Fill + Wide
Reset Display Profile	Yes	Yes, No

3-25

Setup Video
 Select Source Profile
 Edit Source Profile
Edit Display Profile
 Default TV Standard
 Test Images

Setup Video Edit Display Profile
 HDMI Out
Comp. Out Prog. Scan
 Analog Out Stand. Def.

Setup Video...Comp. Out Prog Scan
 Display Aspect Ratio
 Zoom Ratio
 Reset Display Profile

Display Aspect Ratio (Setup : Video : Edit Display Profile : Comp. Out Prog. Scan : Display Aspect Ratio)

See *Display Aspect Ratio* on page 3-22.

Zoom Ratio (Setup : Video : Edit Display Profile : Comp. Out Prog. Scan : Zoom Ratio)

See *Zoom Ratio* on page 3-23.

Reset Display Profile (Setup : Video : Edit Display Profile : Comp. Out Prog. Scan : Reset Display Profile)

Reset Display Profile resets the parameters of the display profile associated with the Component video output connectors to the original settings.

Edit Display Profile: Analog Out Stand. Def.

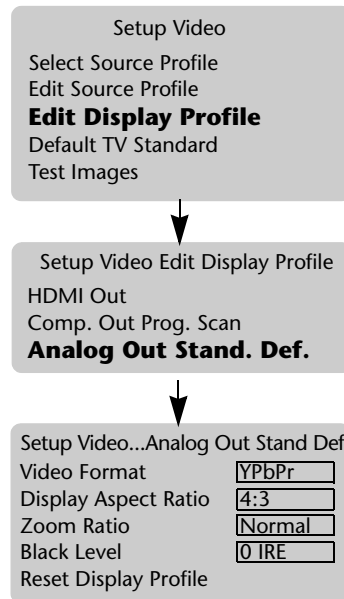

3-26

Analog Out Stand. Def. (Analog Output Standard Definition) parameters control the video format when an SD (480/576i) source is present, the N^o51 Media Player is using the S-Video, Composite or Component video output connector, and the video output switch (on rear panel) is set to **SD video**.

Parameter	Default	Possible Settings
Video Format	YPbPr	YPbPr , Analog RGB
Display Aspect Ratio	4:3	16:9, 4:3, 4:3 P&S
Zoom Ratio	Normal	Normal, Widescreen, Fill, Fill + Wide
Black Level	0 IRE,	0 IRE, 7.5 IRE
Reset Display Profile	Yes	Yes, No

Video Format (Setup : Video : Edit Display Profile : Analog Out Stand. Def. : Video Format)

Video Format is used to set the video format to YPbPr or RGB when a SD (480/576i) source is present and the N^o51 Media Player is using the Component output connector.

Note: A special SCART adaptor cable is needed for Analog RGB mode. In this mode, the Component output uses a separate output for the sync signal (S_c) in addition to R, G and B.

To select a video format:

Press the remote control **up** or **down** button to highlight the desired setting, and press **enter**.

Display Aspect Ratio (Setup : Video : Edit Display Profile : Analog Out Stand. Def. : Display Aspect Ratio)

See *Display Aspect Ratio* on page 3-22.

Zoom Ratio (Setup : Video : Edit Display Profile : Analog Out Stand. Def. : Zoom Ratio)

See *Zoom Ratio* on page 3-23.

Black Level (Setup : Video : Edit Display Profile : Analog Out Stand. Def. : Black Level)

Black Level sets the black level of the video output to 0 IRE or 7.5 IRE for NTSC Component video. The correct or best setting sets the black level to “true black”, but depends on the following factors: the source material, the selected video output format, and the video processor or display. A non-optimum setting can create a displayed image with more noise requiring adjustment to the display’s brightness and contrast.

To set black level compensation:

Use the remote control **up** or **down** button to select the desired setting and press **enter**.

- For Component video, select 0 IRE, if the display supports that mode.
- If the display does not support 0 IRE, select 7.5 IRE.
- CVBS or S-Video always use 7.5 IRE; it is not adjustable.

Reset Display Profile (Setup : Video : Edit Display Profile : Analog Out Stand. Def.: Reset Display Profile)

3-27

Reset Display Profile resets the parameters of the display profile associated with the Composite video output connector to the original settings.

To reset the display profile:

Use the remote control **up** or **down** button to select the desired setting and press **enter**.

Default TV Standard

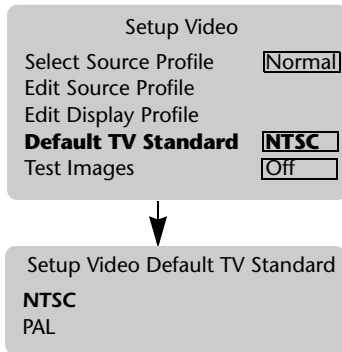

Default TV Standard is used to enable either NTSC or Pal interlaced video format. This allows the user to set the default so that when no disc is inserted, the on screen display is output in the correct standard for their display. When a disc is inserted, the player will switch to the format of the disc.

Parameter	Default	Possible Settings
Default TV Standard	NTSC	NTSC, PAL

NTSC (National Television Standards Committee) is a video format consisting of 480 active lines. It is used in the United States, Canada, and Japan.

PAL (Phase Alternation by Line) is a video format that consists of 576 active lines. It is used in European countries.

To set the default TV standard:

Use the remote control **up** or **down** button to select the desired setting and press **enter**.

3-28

Test Images

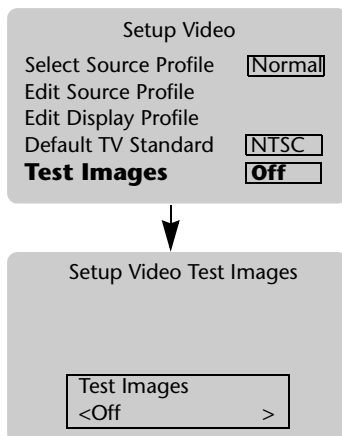

Test images are internally generated by the N°51 Media Player and output to the display device through the active video output port in the selected output format. Each test image is technically perfect (conforms to video industry standards) at the output of the N°51 Media Player and can be used as a system diagnostic to determine any anomalies in the path from the source to the display.

These images should only be used with the N°51 Media Player settings set to 0. The purpose of these images is to setup the display if no setup disc is available.

To use test images:

1. Set the N°51 Media Player video controls to **0**.
2. Select Setup : Video : Test Images.
3. Using the left and right arrow buttons, select a test image to display.
4. Use the image to adjust downstream video components.

If the N°51 Media Player video parameters are to be adjusted, a DVD containing test images must be used, and not the internal Color Bars and Crosshatch test images.

Before Using Test Images

Before using the test images, be sure the associated display and any other devices in the path between the N°51 Media Player and the display are independently calibrated. This separate calibration should not be confused with calibration using the N°51 Media Player generated test patterns. Independent device calibration, resulting in the acceptance of a perfect signal, should be verified using a reference test pattern from a device that is known to be properly calibrated.

When using test images, the N°51 Media Player video parameters should be adjusted to 0.

In most cases, independent device calibration requires a knowledgeable technician and should be left to your system installer.

Color Bars (Setup : Video : Edit Source Profile : Test Images : Color Bars)

Color Bars are used to adjust the Color Tint and Saturation parameters to ensure proper color output on the associated display device.

Before adjusting color controls using the Color Bars test image:

- Activate a source profile (see *Select Source Profile* on page 3-16.)
- Set the N°51 Media Player's Brightness and Contrast parameters to 0.

3-29

To adjust color controls using the Color Bars test image:

1. Select the **Color Bars** test pattern.
2. Evaluate the colors on the associated display device.
3. Adjust the red-to-green color balance in the image using the Color Tint parameter of the associated device.
4. Adjust tonal values using the Saturation parameter of the associated device.

Crosshatch (Setup : Video : Edit Source Profile : Test Images : Crosshatch)

The Crosshatch test image is used to adjust the convergence of the display or to align display geometry size and alignment. Generally, convergence only applies to displays with three (red, green, and blue) CRT guns or to a projection display system with three optical paths.

The Crosshatch test image appears as a matrix of horizontal and vertical white lines on a black background. Each line is comprised of red, green, and blue components. In order to display the lines as white, each CRT gun, or projection system optical path, must have the RGB video components aligned precisely over each other. By

Test Images (continued)

“converging” at the same point, the red, green, and blue components combine exactly to produce white. When the RGB guns are misaligned, the white lines appear to have “ghosts” or “halos”, or in extreme cases, separate into individual red, green, and blue lines.

To adjust convergence:

1. Select the **Crosshatch** test image.
2. Evaluate the image on the associated display device.
3. If the white vertical and horizontal lines appear to have color edges, adjust the display’s RGB gun controls until the white lines are aligned and appear to be white.

To adjust display geometry:

1. Select the Crosshatch test image.
2. Observe the display geometry on the associated display for proper alignment and position. The image should fill the display and appear centered, with all edges visible.
3. If the horizontal and vertical lines appear to be shifted vertically or horizontally, the test pattern is not centered, or all edges are not visible, adjust the display horizontal and vertical controls until the image is centered and all edges are visible.

Disc Parameters

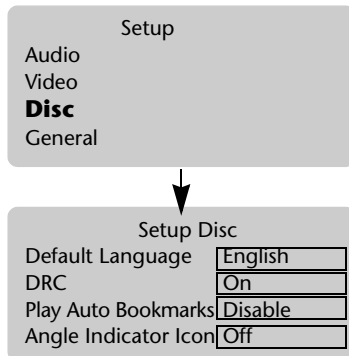

Disc parameters control language, bookmarks and camera angle settings. To access disc parameters, select **Disc** from the Setup menu.

Parameter	Default	Possible Settings
Default Language*	English	See page A-7 for the full list of languages.
DRC	On	On, Off
Play Auto Bookmarks	Disable	Enable, Disable
Angle Indicator Icon	Off	On, Off

* Some discs may exhibit different results depending upon the mastering.

Default Language (Setup : Disc : Default Language)

Default Language refers to the preferred language of the disc. The Default Language menu displays a list of supported languages with the preferred language highlighted. If a source DVD contains a different preferred language, playback will default to that selection.

To select a preferred language:

Press the remote control **up** or **down** button to highlight a language, and press **enter** to select the language.

3-31

DRC (Setup : Disc : DRC)

Use the DRC (Dynamic Range Control) option to decrease the dynamic range of a Dolby Digital-encoded audio source. DRC is used to maintain the clarity of dialogue when played at low volume and is most often used during night time viewing when a quieter viewing environment is desired.

Note

The DRC parameter applies to the analog audio outputs (2-Ch and 5.1 channel outputs), and also to any digital output (SPDIF or HDMI) that is set to PCM. The DRC parameter does not have any effect on digital outputs (SPDIF or HDMI) set to Encoded, since DRC is a function of the audio decoder (in this case, the surround processor that receives the encoded datastream from the No51).

To enable/disable DRC:

Using the remote control **up** or **down** button, highlight the desired setting and press **enter**.

Note

There are certain configurations where DRC will be forced **On** to prevent overloading of the analog outputs:

- Anytime Analog Speaker Config is set to **2-ch Downmix**.
- Anytime the Center, or Surround, or Subwoofer crossover is set to **None**.
- Anytime the crossovers are set such that low frequencies will be redirected to the Front L/R, Center or Surround L/R.

For example:

Front L/R = Full
 Center = 80Hz
 Surround = 80Hz
 Subwoofer = None

Play Auto Bookmarks

(Setup : Disc : Play Auto Bookmarks)

When the Play Auto Bookmarks parameter is set to **Enable**, pressing the drawer button automatically marks the current playback time for future playback. Playback is automatically activated from the bookmarked playback time when the disc is loaded. For more information see “Manual and Automatic Bookmarks” on page 4-17.

To enable/disable automatic bookmarks:

Press the remote control **up** or **down** button to highlight the desired setting, and press **enter**.

3-32

Angle Indicator Icon

(Setup : Disc : Angle Indicator Icon)



Activates and deactivates the Angle Indicator Icon. When set to **On**, the indicator icon appears in the on-screen status bar when playback of a scene recorded from multiple camera angles is in progress. When set to **Off**, the indicator does not appear in the status bar when playback of a scene recorded from multiple camera angles is in progress.

To enable/disable the angle indicator icon:

Press the remote control **up** or **down** button to highlight the desired setting, and press **enter**.

General Parameters

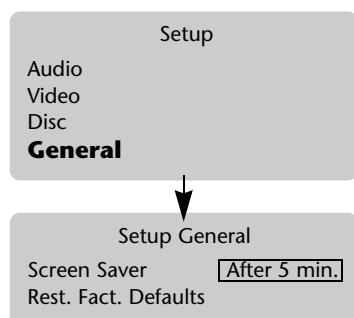

General parameters control the screen saver and factory default settings. To access general parameters, select **General** from the Setup menu.

Parameter	Default	Possible Settings
Screen Saver	After 5 min	After 5 min After 15 min After 30 min After 60 min Off
Rest. Fact. Defaults	Yes	Yes, No

Screen Saver

(Setup : General : Screen Saver)

Activates and deactivates the screen saver.

- When enabled, the screen saver appears when a still frame image has been displayed for more than selected amount of time.
- When **Off** is selected, the screen saver never appears in the on-screen display.

Still frame images displayed on a display device for long periods of time can “burn in” or create “ghost images” on the screen. When the media player is connected to a display device, it is recommended that you set the Screen Saver parameter to On to prevent the appearance of “ghost images” on the screen.

To enable/disable the screen saver:

Press the remote control **up** or **down** button to highlight the desired setting, and press **enter**.

Rest. Fact. Defaults

(Setup : General : Rest. Fact. Defaults)

When the Rest. Fact. Defaults parameter is set to **Yes**, all parameters and user-defined controls are restored to their factory-default settings.

To restore factory settings:

1. Press the remote control **up** or **down** button to highlight the “Rest.Fact.Defaults” setting, and press **enter**.
2. When prompted to confirm the selection, press **enter**.
“Restoring Factory Defaults...” appears in the on-screen display during the restoration process (approximately 20 seconds).

4

Playback Controls

Navigating Disc Menus

Most discs include on-screen display menus that can be used to select disc settings, control playback, or view information about the disc. The descriptions that begin below provide a general overview of disc menus available for each format. These descriptions may differ for some discs within each format.

DVD-V

Includes menus that can be used to activate playback of specific scenes and to select disc settings such as audio track (audio language and output format), subtitle language, and camera angle. The content of DVD-V menus is dependent on how the DVD was mastered. In some cases, certain remote-control buttons can also be used to select these settings without navigating through the disc menu.

Audio CD / DTS CD

Includes tracks on the current CD.

Disc Menu Navigation

The table below provides descriptions of remote control commands that can be used to navigate disc menus. Some commands might not be available for all discs within each format.

Remote Button	DVD-V	Audio CD / DTS CD
menu & top menu	Pressing the menu button opens and closes the disc menu, provided the loaded disc includes a menu. In some cases, pressing the top menu button also opens and closes the menu.	Pressing the menu button displays the track list in the on-screen display with the active track highlighted.
play (▶)	Initiates playback.	
number buttons For more information, see “number buttons” on page 2-13.	<ul style="list-style-type: none"> • Select titles or chapters for playback. • When menu items in the Setup menu are not numbered, pressing a number button selects the menu item in the corresponding position. For instance, pressing the number 1 button selects the first menu item. 	Selects a track with the corresponding number for playback.
enter	<ul style="list-style-type: none"> • Initiates playback of the selected menu item. • Selects highlighted menu item and opens next menu in hierarchy. 	Initiates playback beginning with the selected track.
return	<ul style="list-style-type: none"> • Closes the current menu without activating unsaved settings, and opens the previous menu. • When the first menu screen is open, pressing return performs no function. 	Closes the current menu without activating unsaved settings.
up & down buttons	<ul style="list-style-type: none"> • When a disc menu is open, pressing the up or down button scrolls upward or downward through the current list of menu items. • When menu items exceed the top and bottom margins of the on-screen display, small arrows appear at the top and/or bottom of the display. 	Scrolls upward and downward through the current track list.
left & right buttons	<ul style="list-style-type: none"> • When a disc menu is open, pressing the left or right buttons moves the cursor left or right (or up or down) in the menu. • When the Setup menu is open, pressing the left or right button sets values for the active menu item. 	No effect.
previous button (⏮)	Jumps playback to beginning of the current chapter or previous chapter.	Jumps playback to beginning of the current track or previous track.
next button (⏭)	Jumps playback forward to the next chapter or track.	Jumps playback to the next track.
search	Initiates playback at a specific title, chapter or playback time.	Initiates playback at a specific track or playback time.

Selecting Disc Settings

Some disc menus can be used to select disc settings such as audio track (audio language and output format), subtitle language and camera angle. In some cases, certain remote control buttons can also be used to select these settings without navigating through the disc menu. The ability to use these features with a DVD is dependent on how the DVD was mastered.

audio When a loaded disc is playing, pressing the remote control audio button opens the audio status menu which is used to select audio tracks (audio language and output format).

To select an audio track:

1. When playback is activated, press the **audio** button to display the audio status menu.
The audio status menu indicates the current audio language and output format.
2. When the audio status menu appears, press the **audio** button again to cycle through all audio tracks.
3. When the desired audio track is selected in the on-screen display, press **enter** or **return** to close the status menu, or wait a few seconds and the menu will automatically close and playback will begin.

4-3

subtitle language Pressing the remote control subtitle button opens the subtitle status menu, which is used to select a subtitle language. Subtitle language selection is available for DVD-Vs that were created with subtitles. Changing the subtitle language will only affect the current disc.

To select a subtitle:

1. When playback is activated, press the **subtitle** button to display the subtitle status bar.
 - The status menu indicates the current subtitle, if one is active.
 - If a status menu does not open, subtitle selection might not be available for the loaded disc.
2. When the status menu opens, press the **subtitle** button again to cycle through all subtitle languages for the loaded disc.
3. When the desired subtitle is selected, press **enter** or **return** to close the status menu, or wait a few seconds and the menu will automatically close and playback will begin.

camera angle

Some DVDs contain multiple angles of a particular scene. The remote control **angle** button opens the angle status menu, which is used to select the desired camera angle.

Camera angle selection is available for scenes recorded from multiple camera angles. Camera angle selection is not available for other disc formats or for DVD scenes recorded from one camera angle. In addition, camera angle selection is not available unless playback is activated.

The Angle Indicator Icon parameter (page 3-32) activates and deactivates the indicator. When set to **On**, the indicator appears in the on-screen display when playback of a scene recorded from multiple camera angles is in progress. When set to **Off**, the indicator does not appear in the on-screen display when playback of a scene recorded from multiple camera angles is in progress.

To select a camera angle:

1. When playback is activated, press the **angle** button to open the angle status menu.
 - The angle status menu indicates the number of the selected camera angle and the number of camera angles from which the currently playing scene was recorded. For instance, **angle: 1/2** indicates that camera angle 1 of 2 is selected.
 - If the angle status menu indicates that camera angle 1 of 1 is selected, the currently playing scene was recorded from one camera angle. In this case, camera angle selection is not available.
 - If the angle status menu does not open at the top of the on-screen display, camera angle selection might not be available for the loaded disc.
2. When the Angle bar opens, press the **angle** button again to cycle through all camera angles available for the currently playing scene. The remote control number buttons can also be used to enter the number of the desired camera angle (if known).

Note: The Angle bar automatically closes a few seconds after the last command is received. If this occurs, playback will automatically activate from the selected camera angle.

3. When the desired camera angle is selected, press the **enter** or **return** button to close the menu and activate playback from the selected camera angle, or wait a few seconds and the menu will automatically close and playback will begin.

zoom ratio Pressing the remote control ratio button opens the ratio status bar, which is used to select a video zoom ratio. When the status menu opens, press the ratio button again to cycle through the available zoom ratios.

Zoom Ratio	
Normal	<p>Select Normal when no zoom is desired. The video output from the N°51 to the display is based on the selected Display Aspect Ratio.</p> <ul style="list-style-type: none"> • For 16:9 displays: Widescreen (anamorphic) source content appears using the default aspect ratio on the DVD, and is displayed in a 16:9 aspect ratio. You can optionally zoom and remove the letterboxing caused by viewing a 2.35:1 widescreen (anamorphic) DVD (see <i>Widescreen</i> below). • For 4:3 displays: Widescreen (anamorphic) source content appears in Letterbox format; 4:3 full-frame content appears as full-frame; Pan & Scan content appears as full-frame if 4:3 P&S is selected as the Display Aspect Ratio. (To optionally remove the letterboxing, see <i>Fill</i> below).
Widescreen	<ul style="list-style-type: none"> • Select Widescreen for 16:9 displays only if the source material on the DVD is widescreen (anamorphic) with a 2.35:1 aspect ratio. • If Widescreen is selected, the black bars that otherwise appear at the top and bottom of a 16:9 display are removed for 2.35:1 DVD content by zooming into the picture. Zooming results in a slight cropping of the left and right sides of the image and a small amount of resolution loss due to image scaling; however, there are no geometric distortions and the source material appears without letterboxing.
Fill	<ul style="list-style-type: none"> • For 16:9 displays: Select Fill when viewing the content of a Full-frame (4:3) DVD on a 16:9 display. Black bars on the left and right of the display (pillarboxing), are eliminated by zooming the image and cropping it, top and bottom. Picture resolution is slightly reduced due to scaling; however, there is no geometric distortion, and the image fills the display screen. • For 4:3 displays: Select Fill when viewing the content of a Letterbox DVD on a 4:3 display. Black bars (on the top and bottom of the display) are reduced or eliminated by zooming the image and cropping the sides slightly. Picture resolution is slightly reduced due to scaling; however, there is no geometric distortion, and the image fills the display screen. The DVD will probably be labeled as widescreen (anamorphic). Note that if the source material on the DVD is in an aspect ratio other than 16:9, selecting Fill will not totally remove the letterboxing.
Fill + Wide	<ul style="list-style-type: none"> • Select Fill + Wide for the maximum amount of zoom. This is equivalent to having both Fill and Widescreen zoom modes active at the same time. • Use this mode only when playing a 2.35:1 widescreen DVD on a 4x3 display. This will completely eliminate black bars on the top and bottom of the screen.

Playback Modes

The media player offers a range of playback modes that can be used to control the playback of a loaded disc. The following table indicates the playback modes available for each disc format. However, these modes might not be available for all discs within each format.

Playback Mode	DVD-V	Audio CD (DTS CD)
Play	Available	Available
Pause	Available	Available
Stop	Available	Available
Resume	Available	Not available
Slow Search (slow fwd/rev)	Available	Not available
Fast Search (fwd/rev)	Available	Available
8s prev	Available	Available
Skip	Available	Available
Frame-by-frame	Available	Not available
Search	Title, Chapter, Time	Track, Time
Random**	Not available	Track, Playlist **
Repeat**	Title, Chapter	Disc, Track, Playlist **
A-B Repeat	Available	Available
Playlist	Not available	Track
Bookmark*	Available	Available*
Info	Available	Available

* Automatic bookmarks can not be set for CDs; only manual bookmarks, using the mark and recall buttons can be set.

** If **playlist** is active, only Playlist will be available for Random, and only Playlist and Repeat Track will be available for Repeat.

4-6



Play

The front panel or remote control **play** button is used to start playback of the loaded disc at regular playback speed.

Some discs automatically start playback when switching titles, chapters, or tracks, even if a different playback mode (i.e. random playback) was activated before the switch.

To begin playback:

Press the **play** (▶) button. In some cases, the remote control number buttons can also be used to activate playback of a specific title, chapter, or track.

Pause



The front panel and remote control pause button can be used to activate Pause mode, which pauses playback at the current playback time.

Activating Pause mode creates a still-frame image on the associated display device screen.

To activate Pause mode:

When playback is activated, press the **pause (||)** button.

To deactivate Pause mode:

- Press **play (▶)** or **pause (||)** to deactivate Pause mode and activate playback at the current playback time.
- Press **stop (■)** to deactivate Pause mode and activate Stop mode. When Stop mode is activated, playback cannot be reactivated at the current playback time.

Stop



The front panel and remote control stop button is used to stop playback of the loaded disc.

To activate Stop mode:

When DVD playback is activated, press the **stop (■)** button. In some cases, pressing the stop button activates Resume mode. In this instance, the stop button must be pressed twice in succession to activate Stop mode. When Stop mode is activated, playback cannot be reactivated at the current playback time.

4-7

Resume



The stop button can be used to activate Resume mode, which pauses playback at the current playback time.

To activate Resume mode:

When playback is activated, press the **stop (■)** button. A status bar opens in the on-screen and front-panel displays indicating that Resume mode is activated.

If a status bar does not appear, Resume mode might not be available for the loaded disc. The table on page 4-6 indicates the playback modes available for each disc format.

To deactivate Resume mode:

- Press **play** (▶) to deactivate Resume mode and activate playback at the current playback time.
- When in Resume mode, press **stop** (■) to activate Stop mode. When Stop mode is activated, playback cannot be reactivated at the current playback time.

**Slow Search
(slow fwd/
rev)**

The remote control slow fwd/rev (▶/◀) buttons can be used to activate slow search of a DVD. Audio automatically mutes when slow search playback is activated.

To activate slow search:

- When playback is activated, press the ◀ or ▶ button to start slow search in the selected direction.
- Press the ◀ button to activate slow reverse search at 1/2x regular speed, or repeatedly press the ▶ button to cycle through all available slow forward search speeds – 1/16, 1/8, 1/4 or 1/2 regular playback speed.
- When Pause mode is activated, press the ◀ or ▶ button to activate reverse slow search at 1/2 regular playback speed, or forward slow search at 1/16, 1/8, 1/4 or 1/2 regular playback speed.

To deactivate slow search:

- Press **play** (▶) to deactivate slow search and activate playback at the current playback time at regular speed.
- Press **stop** (■) once to activate Resume mode or twice to activate Stop mode.
- Press the **pause** (||) button to pause slow search at the current disc location.

**Fast Search
(fwd/rev)**

The remote control fwd/rev (▶/◀) buttons can be used to activate fast search, which plays the loaded disc at 2x, 4x, 8x or 16x regular playback speed in the selected direction. Audio is automatically muted when fast search is activated.

To activate fast search:

- When playback is activated, press the ▶ or ◀ button to start fast search in the selected direction.
- Repeatedly press the ▶ or ◀ button to cycle through all available fast search speeds – 2x, 4x, 8x or 16x regular playback speed.
- When Pause mode is activated, each press of the ▶ button activates frame-by-frame playback in the forward direction.

To deactivate fast search:

- Press **play** (▶) to deactivate fast search and activate regular playback speed at the current playback time.
- Press **stop** (■) once to activate Resume mode or twice to activate Stop mode.
- Press **pause** (⏸) to pause fast search at the current disc location.

8s prev

The remote control 8s prev button is used in playback mode to jump eight seconds back in the current playback mode, from which point playback is continued.

- When disc playback is enabled, pressing the 8s prev button to go back eight seconds is a convenient way to see or hear missed content.
- When the media player is in Pause mode, pressing the **8s prev** button will jump playback back eight seconds. However, playback will not be initiated until the **play** (▶) or **pause** (⏸) button is pressed.

Frame-by-frame

The remote control pause (⏸) and fwd (▶▶) buttons can be used to activate frame-by-frame playback, which plays the loaded disc one frame at a time in the forward direction. Audio automatically mutes when frame-by-frame playback is activated.

4-9

To activate frame-by-frame playback:

1. When DVD playback is activated, press **pause** (⏸) to pause playback at the current playback time.
2. When Pause mode is activated, press and release the ▶▶ button to activate forward frame-by-frame playback. The picture on the associated display device screen will advance one frame in the forward direction.
3. Continue pressing and releasing the ▶▶ button to continue frame-by-frame.

To deactivate frame-by-frame playback:

- Press **play** (▶) to activate playback at the current playback time.
- Press **stop** (■). In some cases, pressing the stop button activates Resume mode. In this instance, the stop button must be pressed twice in succession to activate Stop mode. When Stop mode is activated, playback cannot be reactivated at the current playback time.

Search The remote control **search** button can be used to activate Search mode, which activates playback of a specific title, chapter, track or time on the loaded disc. The table on page 4-6 indicates the Search modes available for each disc format.

Search Modes	
Title	Activates playback of the first chapter in the selected title.
Chapter	Activates playback of the selected chapter in the currently playing title.
Track	Activates playback of the selected track on a CD.
Time	Activates playback at the selected playback time (minutes: seconds) in the currently playing title, chapter or track. This Search mode is not available unless playback or Pause mode is activated.

To activate Search mode:

1. Press the remote control **search** button to activate Search mode.
 - The time Search mode is not available unless playback or pause mode is activated.
 - A search bar opens to indicate the value of the current Search mode.

current title : 5
search title : _ _

2. Press the **search** button again to cycle through all Search modes available for the loaded disc. The table on page 4-6 indicates the Search modes available for each disc format.
3. When the desired Search mode is selected, press the remote control number buttons to enter a search value. For example:

- To enter title 6, press the number 6 button.

current title : 5
search title : _ 6

- To enter track 16, press the number 1 button, then the number 6 button.

current track : 5
search track 1 6 _

- To enter a playback time of 16 minutes and 20 seconds, press the number 1 button, the number 6 button, the number 2 button, then the number 0 button.

current time : _ _ : <u>3</u> <u>6</u> : <u>1</u> <u>2</u> search time : _ _ : <u>1</u> <u>6</u> : <u>2</u> <u>0</u>

- Press the remote control **delete** button to clear an incorrect search value.
4. When the desired search value is entered, press the **enter** or **play** (▶) button to confirm input and activate playback at the selected playback time, or press the **return** button until the Search mode closes.
 - If a valid search value was entered, playback will activate at the selected title, chapter, track or playback time.
 - If an invalid search value was entered, the search bar will close without activating playback.

Random The remote control **random** button is used to activate playback of the loaded CD in a random order of tracks, beginning with the currently playing track.

4-11

Random playback is automatically deactivated when:

- Repeat playback or Playlist mode is activated.
- The **stop**, **repeat**, **A-B**, **drawer**, **standby** or **power** button is pressed.

To activate random playback:

1. When playback is activated, press the remote control **random** button.
 - Random track playback will automatically activate, beginning with the currently playing track.
 - If a status bar does not open at the top of the on-screen display, random playback might not be available for the loaded disc. The table on page 4-6 indicates the Random playback modes available for each disc format.
2. When the status menu opens, repeatedly press the **random** button to the cycle through all random playback modes available for the loaded disc.
3. When the desired random playback mode is selected, press **enter** or **return** to close the menu and activate the selected random playback mode, or wait a few seconds and the menu will automatically close and random playback will automatically begin.
4. When random playback is in progress:
 - Press the remote control previous (⏮) button to return to the beginning of the currently playing track.

- Press the remote control next (▶▶)button to skip to the beginning of the next randomly selected track.

To deactivate random playback:

Press **random** to deactivate random playback. The following buttons will also deactivate random playback: **stop** (■) (or Resume mode), **drawer**, **random**, **A-B**, **drawer**, **standby** or **power**. In some cases, the **stop** button must be pressed twice in succession to activate Stop mode. When Stop mode is activated, playback cannot be reactivated at the current playback time.

Repeat The remote control **repeat** button can be used to activate repeat playback of the currently playing title, chapter, track or playlist. The table on page 4-6 indicates the repeat playback modes available for each disc format.

Repeat playback is automatically deactivated when:

- Random playback or A-B repeat playback is activated.
- The remote control stop, random, A-B, drawer, standby or power button is pressed and a CD is playing.
- The remote control stop (■)(or Resume mode), previous (◀◀), next (▶▶), fwd/rev (▶▶/◀◀), slow fwd/rev (▶▶/◀), 8s prev, drawer, random, A-B, standby or power button is pressed.

4-12

Repeat Playback Modes	
Title	Activates repeat playback of the currently playing title.
Chapter	Activates repeat playback of the currently playing chapter.
Track	Activates repeat playback of the currently playing track.
Playlist	Activates repeat playback of the currently playing playlist. Repeat playlist playback is not available unless playlist playback is activated when the repeat button is pressed.

To activate repeat playback:

1. Make sure playback of the desired title, chapter, track or playlist is activated.

Repeat playlist playback is not available unless playlist playback is activated when the repeat button is pressed.

2. When playback is activated, press the **repeat** button to open the repeat status menu.
 - The status menu indicates the selected Repeat mode.
 - If the status menu does not open, repeat playback might not be available for the loaded disc. The table on page 4-6 indicates the repeat modes available for each disc format.

3. When the status bar opens, press the **repeat** button again to cycle through all Repeat modes available for the loaded disc.
 - If playlist playback was activated when the **repeat** button was pressed, repeat playlist playback is available. Other repeat modes are not available.
 - The status bar automatically closes a few seconds after the last command is received. When this occurs, the selected Repeat mode is automatically activated.

To deactivate repeat playback:

- Press the remote control **repeat** button, select **Repeat Off** from the status menu, and press **enter**.
- Press the **stop** (■)(or Resume mode), **drawer**, **random**, **A-B**, **drawer**, **standby** or **power** button. In some cases, the stop button must be pressed twice in succession to activate Stop mode. When stop mode is activated, playback cannot be reactivated at the current playback time.

A-B Repeat

The remote control **A-B** button is used to activate A-B repeat playback from a user-defined start time (point A) to a user-defined end time (point B).

To activate A-B repeat playback:

1. When playback is activated, press the **A-B** button at the desired start time (point A). A status bar will open in the front-panel display to indicate that a start time has been selected. The status menu displays the time of point A and the current playtime.
2. Press the **A-B** button again at the desired end time. The status bar indicates the start time (point A), the end time (point B), and A-B repeat playback is automatically activated. Repeat playback of the user-defined playback loop continues until A-B repeat playback is deactivated.

00:05:33 A -
 00:05:42

00:05:33 A -
 00:06:10 - B

A - B off

To deactivate A-B repeat playback:

Press the remote control stop (■)(or Resume mode), previous (⏮), next (⏭), fwd/rev (⏩/⏪), slow fwd/rev (⏩/⏪), 8s prev, drawer, random, A-B, standby or power button. In some cases, the stop button must be pressed twice in succession to activate Stop mode. When stop mode is activated, playback cannot be reactivated at the current playback time.

Playlist The remote control **playlist** button initiates Playlist mode which is used to create a playlist for a loaded CD, save a playlist, or activate the playback of an existing playlist.

- A playlist is a user-defined playback order of tracks.
- When creating a playlist, the appearance of the playlist mode depends on the currently inserted media.

Playlist navigation commands:

Button	Command
delete	<ul style="list-style-type: none"> • Clears the currently highlighted file in the playlist. • Deletes the whole playlist when “Delete Playlist” is selected and the enter button is pressed.
enter	<ul style="list-style-type: none"> • Adds the selected file to the playlist. • Deletes the whole playlist when the “Delete Playlist” entry is highlighted.
number buttons (0-9)	<ul style="list-style-type: none"> • Directly inputs files into the playlist. The entered numbers correspond to files, or files within a selected group.
play	<ul style="list-style-type: none"> • Saves and activates playback of the current playlist beginning with the first entry. • When a playlist is already activated, pressing the play button initiates playback at the currently highlighted entry.
playlist	<ul style="list-style-type: none"> • Activates or deactivates playlist mode, which is used to create a playlist, save a playlist or initiate playback of a playlist.
return	<ul style="list-style-type: none"> • Saves the playlist.
up & down buttons	<ul style="list-style-type: none"> • Scroll upward and downward through files or playlist items.
left & right buttons	<ul style="list-style-type: none"> • When the list of files (on the left) is active, pressing the remote control right button deactivates the cursor over the list of files and activates the cursor in the playlist (on the right). • When the playlist cursor is active, pressing the remote control left button deactivates the playlist cursor and activates the cursor over the list of files.

Playlist Requirements

Format(s)	Playlists	Requirements	Storage
Audio CD & CD-RW/R	One playlist per disc.	Playlists cannot: <ul style="list-style-type: none"> • Include more than 999 tracks. • Include values that are not included on the loaded disc. 	<ul style="list-style-type: none"> • Playlists can be stored for up to 1000 discs. • Playlists are automatically deleted when factory-default settings are restored.

To create a playlist:

- When a CD is loaded, press the remote control **playlist** button to initiate playlist mode.
 - The on-screen display opens to display a split window. The left side of the split window contains a list of tracks that are available for adding to the playlist. The right side of the split window displays the playlist.
 - The left side of the window is used to display the contents of discs with a hierarchical file structure. To navigate the list, use the remote control up, down, enter and return buttons.
- Select a track to add to the playlist by:
 - Pressing the remote control **up** and **down** buttons to scroll upward or downward through the list until the desired track is highlighted.
 - Entering the desired track number using the remote control number buttons.
- When the desired track is highlighted, press the remote control **enter** button to add the selection to the playlist.
 - The new track is inserted beneath the cursor in the playlist regardless of the cursor's location.
 - The number of tracks displayed in the playlist is limited to a maximum of eight lines. Small arrows on the top or bottom of the list indicate the presence of further tracks.
- When the desired tracks have been entered, press the **play** or **playlist** button to save the playlist and activate playlist playback.

To sort tracks in a playlist:

1. When a CD is loaded, press the remote control **playlist** button to initiate playlist mode.

The list containing tracks that are available for adding to the playlist is displayed on the left side of the on-screen display. The right side of the on-screen display shows the existing playlist.

2. When the playlist opens, press the remote control **right** button to activate the playlist cursor.
3. Select a track in the playlist to sort by pressing the remote control **up** and **down** buttons to scroll upward or downward through the playlist until the desired track is highlighted.
4. When the desired track is highlighted, press the remote control **enter** button. Up and down arrows appears to the right of the cursor to indicate sort mode has been entered.

Sort mode cannot be entered unless there is more than one track in the playlist.

5. Using the remote control up and down buttons, move the cursor to the desired position and press the **enter** button to reposition the track and deactivate sort mode.

4-16

To delete tracks in a playlist:

1. When a CD is loaded, press the remote control **playlist** button to initiate playlist mode.

The list containing tracks that are available for adding to the playlist is displayed on the left side of the on-screen display. The right side of the on-screen display shows the existing playlist.

2. When the playlist opens, press the remote control **right** button to activate the playlist cursor.
3. Select a track in the playlist to delete by pressing the remote control **up** and **down** buttons to scroll upward or downward through the playlist until the desired track is highlighted.

Entering the desired track number using the remote control number buttons.

4. When the desired track is highlighted, press the remote control **delete** button.

To delete a whole playlist:

Highlight the "Delete Playlist" entry and press enter.

Manual and Automatic Bookmarks**Manual Bookmarks**

The remote control **mark** button is used to create a manual bookmark at the current playback time. Later, disc playback can be started from the bookmarked playback time.

- When a manual bookmark is set, “bookmark set” appears in the status bar for three seconds.
- Manual bookmarks can be stored for up to 1000 discs. The least recently used bookmark is automatically deleted when a manual bookmark is created and the upper manual bookmark limit has been reached.
- Manual bookmarks can be created for both DVDs and CDs.

To create a manual bookmark for a DVD or CD:

With a DVD or CD loaded and the media player in Play mode at the desired bookmark time, press the **mark** button. The message “bookmark set” appears in the status bar for three seconds, indicating that a manual bookmark has been created at the current playback time.

Automatic Bookmarks

4-17

Pressing the **drawer** button creates an automatic bookmark at the current playback time whenever the media player is in Play, Pause, or Resume mode. Bookmarks allow DVD viewing from the last playback location.

- When an automatic bookmark is set, no special message appears in the on-screen or front panel display.
- To begin or resume playback using an automatic bookmark, the Play Auto Bookmark parameter must be enabled in the Setup : Disc menu before loading the disc.
- Automatic bookmarks can be stored for up to 1000 discs. The least recently used bookmark is automatically deleted when an automatic bookmark is created and the upper automatic bookmark limit has been reached. An automatic bookmark is also deleted after it has been used to start playback.
- Automatic bookmarks can not be created for CDs. To create a bookmark for a CD, see *Manual Bookmarks* above.

To create an automatic bookmark for a DVD:

With a DVD loaded and the media player in Play, Pause or Resume mode, press the **drawer** button to create an automatic bookmark at the current playback time. No special message appears in the on-screen display or status bar. The bookmark is automatically stored in memory.

To start DVD or CD playback using a manual bookmark (Option 1):

1. Load the bookmarked DVD or CD.
2. When the DVD or CD is loaded, press the **recall** button to start playback from the bookmarked playback time. A status bar opens in the on-screen display, and displays “bookmark recalled” for three seconds to indicate that bookmarked playback is activated.

If no bookmark has been created for the loaded disc, performing this step will have no effect.

To start DVD or CD playback using a manual bookmark (Option 2):

1. Place the bookmarked disc in the open drawer. Do not close the drawer.
2. Press the **recall** button. The drawer automatically closes, loads the DVD or CD, and begins playback from the bookmarked playback time. A status bar displaying “bookmark recalled” appears for three seconds to indicate that bookmarked playback is activated.

To start DVD playback using an automatic bookmark:

1. Ensure that the **Play Auto Bookmarks** parameter is enabled in the Setup : Disc menu.
2. Load the bookmarked DVD. Playback starts automatically at the automatic bookmark.

-
- Info Mode** The remote control **Info** button is used to activate or deactivate an Info status bar that provides information about the loaded disc, or general status information. The type of disc-specific information displayed depends on the disc format.
- When an Info status bar is opened in the on-screen display, a subset of the information is displayed on the front panel display.
 - Info status bars are available when Playback, Pause or Stop mode is activated. Info status is also available in resume mode when the loaded disc is a DVD-V. Info status is not available for other disc types in resume mode.
 - When an Info status bar is displayed, repeatedly pressing the Info button cycles through the available disc-specific and general information.
 - Pressing the **return** button closes the status bar. Repeatedly pressing the Info button also closes the Info status bar.

To display an Info status bar:

1. With a disc loaded in playback, pause or resume mode, press the remote control **Info** button. (Resume available for DVD-V only.)
2. When the Info bar opens, repeatedly press the remote control **Info** button to cycle through available information for the loaded disc.

4-19

To close an Info status bar:

Press the remote control **Info** button repeatedly until the status bar closes, or press the **return** button.

DVD-V Info status in Play, Pause, Resume or Stop mode

The following table displays information as it appears in the Info status bar and front-panel display when a DVD-V is in Play, Pause, Resume or Stop mode.

Disc	Info Status Bar	Front panel Display
DVD-V loaded in Play, Pause, or Resume Mode	<i>Dolby Digital:</i> DVD-V DOLBY DIGITAL x/x.x or DOLBY DIGITAL x/x	DVD DDx/x.x or DVD DDx/x
	<i>DTS:</i> DVD-V DTS x/x.x or DTS x/x	DVD DTSx/x.x or DVD DTSx/x
	<i>PCM:</i> DVD-V LPCM x/x.x	DVD PCMx/x.x
	<i>Dolby Digital:</i> Sampling: xxK (values for kHz: 48) Bit Rate: x kbps	SAMPL. xxK
	<i>DTS:</i> Sampling: xxK (values for kHz: 48 and 96) Bit Rate: x kbps	SAMPL. xxK
	<i>PCM:</i> Sampling: xxK (values for kHz: 48 and 96) Bit Rate: x kbps	SAMPL. xxK
	Repeat Title Repeat Chapter A-B Repeat Normal Playback	REPEAT TITLE REPEAT CHAPT A-B REPEAT NORMAL PLAY
	Title: xx/xx Chapter: xx/xx	CHAPT xx/xx
	Title Elapsed Time: xx:xx:xx Title Remaining Time: xx:xx:xx	TITLE REMAIN xx:xx:xx
	Chapter Elapsed Time: xx:xx:xx Chapter Remaining Time: xx:xx:xx	CHAPT REMAIN xx:xx:xx
	Video Resolution: 1080i60 Video Resolution: 1080i50 Video Resolution: 720p60 Video Resolution: 720p50 Video Resolution: 576i50 Video Resolution: 576p50 Video Resolution: 480i60 Video Resolution: 480p60	RES 1080i60 RES 1080i50 RES 720p60 RES 720p50 RES 576i50 RES 576p50 RES 480i60 RES 480p60
	Comp YPbPr CVBS Comp RGB CVBS Comp YPbPr HDMI YCbCr HDMI RGB	COMP YPbPr CVBS COMP RGB CVBS COMP YPbPr HDMI YCbCr HDMI RGB

**CD Info
status in
Play, Pause
or Stop
mode**

The following table displays information as it appears in the Info status bar and front-panel display when a CD is in Play, Pause or Stop mode.

Disc	info Status Bar	Front panel Display
CD loaded in Stop Mode	CD Audio	CD AUDIO
	DTS CD DTS x/x.x	CD DTSx/x.x
	<i>CD Audio:</i> Sampling: xxK (values for xxK: 44.1) Bit Rate: xx kbps	SAMPL. xxK
	<i>DTS CD:</i> Sampling: xxK (values for xxK: 44.1)	SAMPL. xxK
	Repeat Disc Repeat Track A-B Repeat Random Track Normal Playback	REPEAT DISC REPEAT TRACK A-B REPEAT RANDOM TRACK NORMAL PLAY
	Total Disc Time: xx:xx:xx Track: xx/xx	TRACK xx/xx
	Track Elapsed Time: xx:xx:xx Track Remaining Time: xx:xx:xx	TRACK REMAIN xx:xx:xx
	Video Resolution: 1080i60 Video Resolution: 1080i50 Video Resolution: 720p60 Video Resolution: 720p50 Video Resolution: 576i50 Video Resolution: 576p50 Video Resolution: 480i60 Video Resolution: 480p60	RES 1080i60 RES 1080i50 RES 720p60 RES 720p50 RES 576i50 RES 576p50 RES 480i60 RES 480p60
	Comp YPbPr CVBS Comp RGB CVBS Comp YPbPr HDMI YCbCr HDMI RGB	COMP YPbPr CVBS COMP RGB CVBS COMP YPbPr HDMI YCbCr HDMI RGB

4-21

Note: Video resolution in the above table refers to the resolution of the on-screen display.

5 Troubleshooting & Maintenance

Troubleshooting

Incorrect operation is sometimes mistaken for malfunction. If problems occur, see this section for troubleshooting information. If problems persist, contact your Mark Levinson dealer.

No Power

1. Examine the **power cord** to ensure that it is connected to both the **~ac mains connector** and an **electrical outlet**.
2. Make sure the N°51 is powered on with the **power button**.
3. Make sure the N°51 is **not** in standby.
4. Make sure display intensity has not been set to **off** (0%), deactivating the front panel display.
5. Examine the electrical circuit breaker to ensure that power is being supplied to the electrical outlet to which the N°51 is connected.
6. Make sure that you are using the properly rated power cord for your area/country.

5-1

No Remote Control Operation

1. Eliminate obstructions between the remote control IR transmitter and the front panel display IR receiver/transmitter.
2. Make sure the IR input connector is *not* being used.
3. Make sure the remote control IR transmitter LED lights when remote control buttons are pressed, indicating that IR signals are being transmitted.
4. Make sure the remote control is positioned within 17 feet (5m) of the front panel display IR receiver/transmitter. If the N°51 is placed inside a glass cabinet, tinted glass will reduce the remote control range.
5. Make sure the remote control signal is being received at the front panel display IR receiver/transmitter at a reasonable angle.
6. Make sure the front panel display IR receiver/transmitter is not exposed to strong sunlight, halogen light, or fluorescent light. This can cause IR reception to become unreliable.
7. Replace the remote control batteries.

No Main Output

1. Examine audio cables to ensure a solid connection between the N°51 and associated components.
2. Make sure master volume is set to an audible level.
3. Make sure mute is deactivated.
4. Make sure the N°51 main output connectors are connected to an operational power amplifier, and that the associated power amplifier is connected to operational loudspeakers.
5. Make sure all associated components are powered on and connected to electrical outlets.
6. Make sure the associated component connected to the selected input is producing an input signal.
7. Contact an authorized Mark Levinson dealer.

No Video Output

1. Examine the video cables to ensure a solid connection between the N°51, the associated components and the display.
2. Examine the settings on the display to ensure the correct settings and/or inputs are utilized.
3. Make sure that the three-position, video output switch on the rear panel of the N°51 is in the correct position for the video output that is desired. For more information, see “Video Output Switch” on page 3-14.
4. Contact an authorized Mark Levinson dealer.

**No Audio and/or
Video Output
Using HDMI
Output**

1. Examine the HDMI cable from the N°51 to the associated components and the display. Check that the HDMI cable is properly connected and seated in the HDMI input and output ports.
2. Make sure that the three-position, video output switch on the rear panel of the N°51 is in the HDMI (bottom) position. For more information, see “Video Output Switch” on page 3-14.
3. Review the HDMI video settings in the Video Setup menu. For more information, see “Edit Display Profile: HDMI Out” on page 3-20.
4. Review the HDMI audio settings in the Audio Setup menu. For more information, see “Outputs: HDMI Audio Preferences” on page 3-3.
5. Contact an authorized Mark Levinson dealer.

-
- If All Else Fails...**
1. Power cycle the N°51, waiting at least 10 seconds between powering the N°51 off and on.
 2. Restore factory-default settings (See “Restoring Factory-default Settings” below).
 3. Contact an authorized Mark Levinson dealer.
 4. Contact Mark Levinson Customer Service at 781-280-0300 or www.marklevinson.com.

Restoring Factory-default Settings

Performing this procedure restores all parameters and user-defined controls to their factory-default settings.

To restore factory-default settings:

1. Press the remote control **setup** button.
2. Use the remote control **up & down** buttons to highlight **General** in the Setup menu, then press the remote control **enter** button.
3. Use the remote control **up & down** buttons to highlight the **Rest. Fact. Defaults** option, then press the enter button.
4. Use the left or right remote control button to highlight Yes, then press the remote control **enter** button.

“Restoring Factory Defaults...” appears in the on-screen display.

5. When the on-screen display **General** menu reappears, press the remote control **setup** button to close all menus.

Alternate method to restore factory-default settings:

1. Turn the unit off with the **power** button.
2. Press and hold the **standby** button.
3. While continuing to hold the **standby** button, turn the unit on with the **power** button.
4. Once text appears on the front-panel display, release the **standby** button.
5. Once default settings have been restored, “SET DEFAULT” will appear on the front-panel display and the unit will automatically enter Standby mode.
6. Press the **standby** button to exit Standby mode. When the unit boots up, all settings will be at their factory defaults.

Care & Maintenance

The N°51 requires routine care and maintenance to ensure optimal performance. The bulleted items in this section indicate maintenance procedures that should be performed on a regular basis.

Note Failure to perform the maintenance procedures included in this section may void the manufacturer's warranty and/or standard repair policies.

- To remove dust from the N°51 exterior surface, use a feather duster or a low-pressure blower.
- To remove dirt and fingerprints from the N°51 exterior surface, use a soft, lint-free cloth. DO NOT use metal polish or a cloth made with steel wool.

If needed, this cloth can be dampened with isopropyl alcohol. DO NOT dampen the cloth with Benzene, acetone-based cleaners, and other commercial cleaners.

Wipe the N°51 exterior surface in the same direction as the grain of the brushed aluminum.

5-4

Caution! DO NOT apply liquid directly to the N°51 exterior surface. Doing so may damage electrical components.

- Replace the remote control batteries as needed. See "Remote Control Batteries" on page 1-10 for additional information.

See "Installation Considerations" on page 1-9 for information about preventative maintenance.

Specifications

Audio Section

Audio Frequency Response	10Hz to 20kHz, +0.1dB to -0.5dB
*THD + Noise	0.002% at 1kHz, 0dBFS (10Hz-30kHz), XLR 0.003% at 1kHz, 0dBFS (10Hz-30kHz), RCA
*Signal-to-Noise Ratio	102dB (10Hz-30kHz)
Digital to Analog Converter Type	24-bit/192kHz PCM multibit $\Sigma\Delta$
Digital Audio Sample Rates	44.1, 48, 88.2, and 96kHz (16 to 24 bits)
Channel Separation	Better than 110dB
Intermodulation Distortion (SMPTE IMD)	<0.005%
Maximum Output - XLR (0dBFS signal)	4V ("Fixed" volume mode) 14V ("Variable" volume mode)
Maximum Output - RCA (0dBFS signal)	2V ("Fixed" volume mode) 7V ("Variable" volume mode)
*Dynamic Range	102dB (10Hz-30kHz)
Digital Audio Output Connectors	One AES/EBU on XLR One S/PDIF coaxial on RCA One EIAJ optical One HDMI multi-pin (All digital audio outputs conform to IEC-958 and S/PDIF standards.)
Analog Audio Output Connectors	One balanced stereo pair on XLR One single-ended stereo pair on RCA Six single-ended multichannel on RCA

* Note: These measurements use a 10Hz-30kHz bandwidth filter.

Video Section

HDMI Video Resolution 1080i, 720p, 480/576i, 480/576p

Composite and S-Video (NTSC/PAL)

Impedance 75Ω

Composite Output Level 1.0V p-p

S-Video Output Levels Y (Luma) = 1.0V p-p (700mV p-p video),
C (Chroma) = 300mV p-p

Bandwidth >4.2 MHz, +/-0.1dB (NTSC)
>5.0 MHz, +/-0.1dB (PAL)

Differential Gain <0.5% (NTSC)
<1.4% (PAL)

Differential Phase <2.0° (NTSC)
<2.5° (PAL)

K Factor <0.6% (NTSC)
<0.4% (PAL)

Signal to Noise Ratio >60dB

Composite Sync Embedded

Component Video (YPbPr [Sync on Y] or SCART [RGB + Sync] SD)

Impedance 75Ω

Y Output Levels 1.0V p-p with 75Ω load (700mV p-p video)

Pb, Pr Output Levels +/-350mV with 75Ω load (700mV p-p)

RGB Output Levels 1.0V p-p with 75Ω load (700mV p-p video)

Y Bandwidth >6.0 MHz, +/-0.1dB (Interlaced)
>12.0 MHz, +/-0.1dB (Progressive Scan)

Pb, Pr Bandwidth >4.0 MHz, +/-0.1dB (Interlaced)
>8.0 MHz, +/-0.1dB (Progressive Scan)

RGB Bandwidth >6.0 MHz, +/-0.1dB (Interlaced)

Stopband >-55dB @ 216 MHz

Clamping Back porch clamped to 0V, DC-coupled output

Sync Sync on Y

Video Output Connectors One Composite on RCA
One S-Video
One Component (Y/G, Pb/B, Pr/R and Sc) on four 75Ω BNC
Two SCART trigger outputs (AV and RGB) on mini jacks
One HDMI multi-pin
One Composite monitor output on RCA

Other

IR Input	12V
Trigger Input	12V
Power Requirements	100/120/220/230/240 VAC, 50/60 Hz
Power Consumption	90 Watts
Operating Temperature	0°C to 35°C
Overall Dimensions	Width: 17.75 inches (450.85mm) Height: 5.864 inches (148.95mm) Depth: 19.20 inches (487.68mm)
Weight	Weight: 46.5 lb. (21.09kg)
Rack Mounting	Refer to the rack mount instructions (INSTR, RACK MNT, ML, 3U) included in the optional rack mounting kit.

All specifications are subject to change without notice.

Declaration of Conformity

Application of Council Directive(s):

89/336/EEC and 73/23/EEC as amended.

Standard(s) to which Conformity is Declared:

-
- | | |
|--|---------------------------------|
| • EN 55013: 2001 | • EN 61000-3-2: 2000 |
| • EN 55020: 2002 | • EN 61000-3-3: 1995 + A1: 2001 |
| • EN 55022: 1994 + A1: 1995 + A2: 1997 | • EN 60065: 1998 |
| • EN 60825 - 1: 1994 + A1: 2002 + A2: 2001 | |
-

Manufacturer:

Harman Specialty Group
3 Oak Park
Bedford, MA 01730-1413 USA

The equipment identified here conforms to the Directive(s) and Standard(s) specified above.

Type of Equipment:

media player

Model(s):

Mark Levinson N°51

Date:

August 2005

Harman Specialty Group
Vice President of Engineering
3 Oak Park
Bedford, MA 01730-1413 USA
Telephone: 781-280-0300
Fax: 781-280-0490
www.harmanspecialtygroup.com

Audio Menu Tree

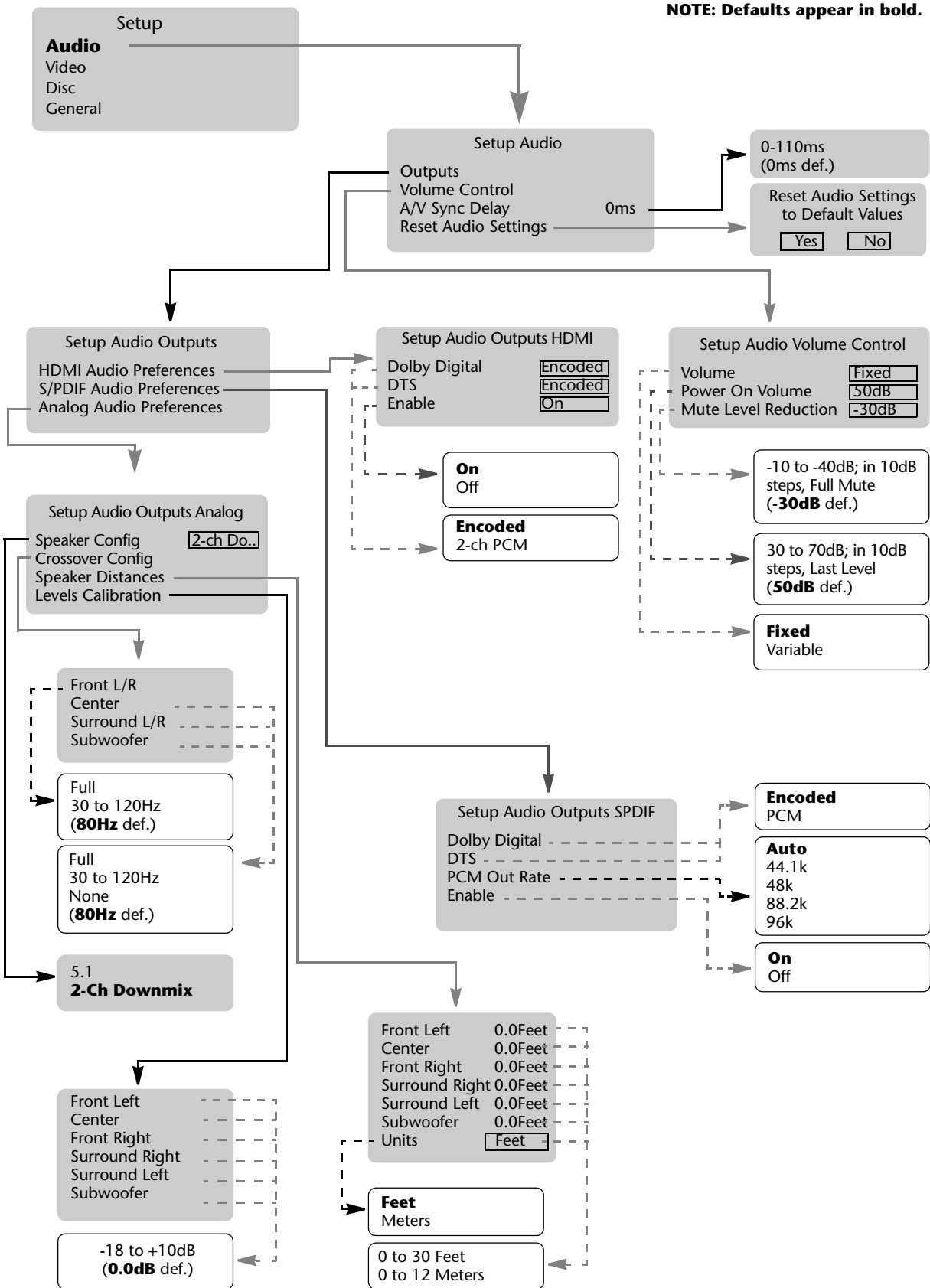

Video Menu Tree

Setup

- Audio
- Video**
- Disc
- General

NOTE: Defaults appear in bold.

Setup Video Select Source Profile

- Normal**
- Film
- Video/TV
- Photo
- Custom

Setup Video

- Select Source Profile
- Edit Source Profile
- Edit Display Profile
- Default TV Standard
- Test Patterns

NTSC
PAL

Off
Color Bars
Crosshatch

Setup Video Edit Source Profile

- Normal
- Film
- Video/TV
- Photo
- Custom

Setup Video Edit Display Profile

- HDMI Out
- Comp. Out Prog. Scan
- Analog Out Stand. Def.

RGB Normal
RGB Expand
YCbCr4:2:2
YCbCr4:4:4

SD
PS
HD 720p
HD 1080i

16:9
4:3
4:3 P&S

Normal
Widescreen
Fill
Fill + Wide

Reset Display Profile to Default Values?

Setup Video ...HDMI Output

- Video Format
- Resolution
- Display Aspect Ratio
- Zoom Ratio
- Reset Display Profile

Setup Video ...Comp Out Prog Scan

- Display Aspect Ratio
- Zoom Ratio
- Reset Display Profile

Setup Video ... Analog Out Stand

- Video Format
- Display Aspect Ratio
- Zoom Ratio
- Black Level
- Reset Display Profile

Reset Display Profile to Default Values?

0 IRE
7.5 IRE

Normal
Widescreen
Fill
Fill + Wide

16:9
4:3
4:3 P&S

YPbPr
Analog RGB

Brightness 0
Contrast 0
Color Tint 0
Saturation 0
Film Mode
Deinterlacing Automatic
Compensat.+ Level 0
Noise Reduction Off
Chroma Sharpness Off
Luma Sharpness Off
- Reset Source Profile

Reset Display Profile to Default Values?

Peaking
Transient Improvement

0 to 3
0 to 9

On
Off

0 to 7 (**4** def.)

Weave
Adaptive
Compensat.
Compensat.+

Reset Display Profile to Default Values?

Normal
Widescreen
Fill
Fill + Wide

16:9
4:3
4:3 P&S

-32 to 31 (**0** def.)

-15 to **0**

-8 to 7 (**0** def.)

On 2-2
On 3-2
On 2-2+3-2
Automatic
Off

A-6

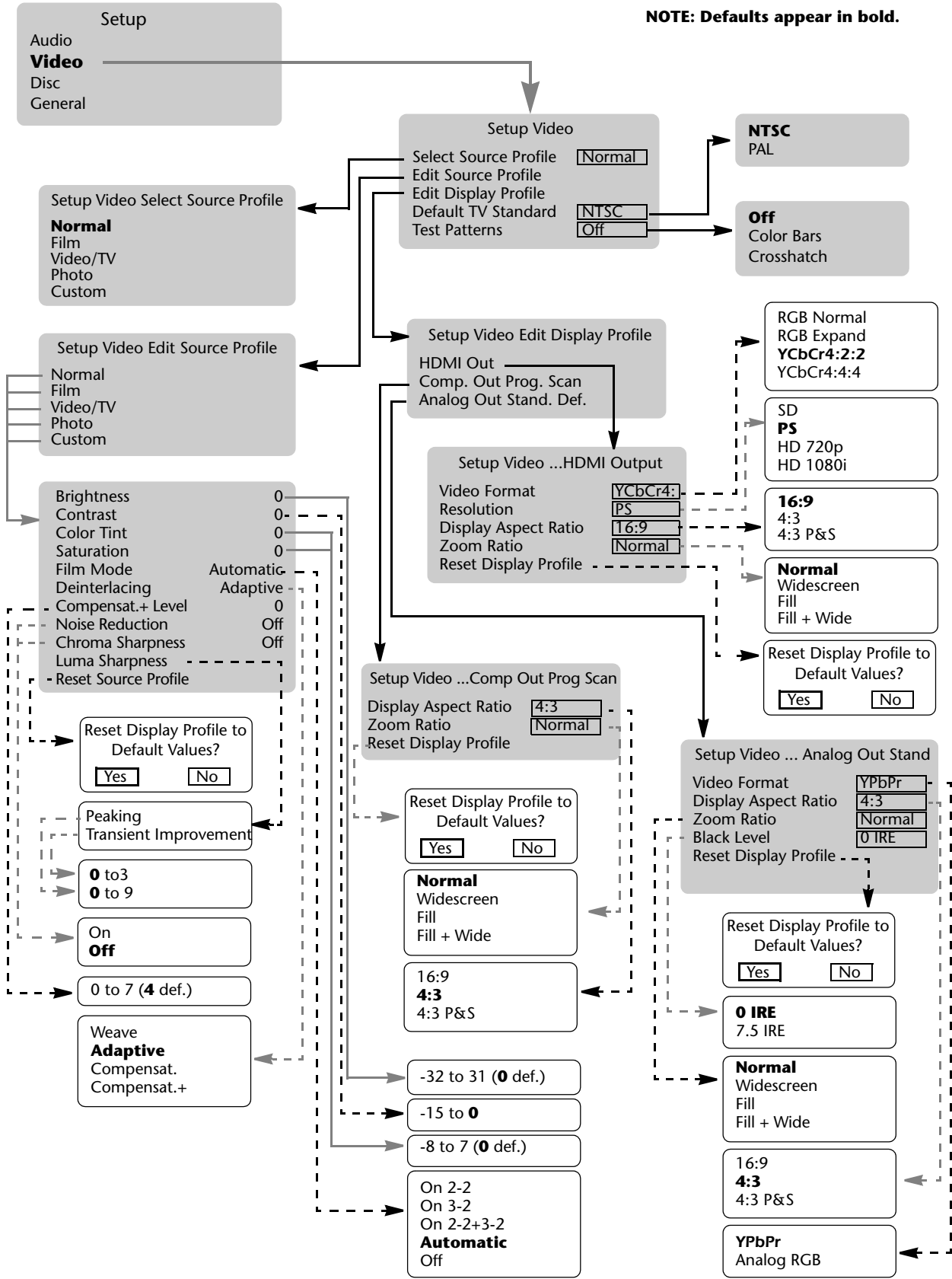

Disc Menu Tree

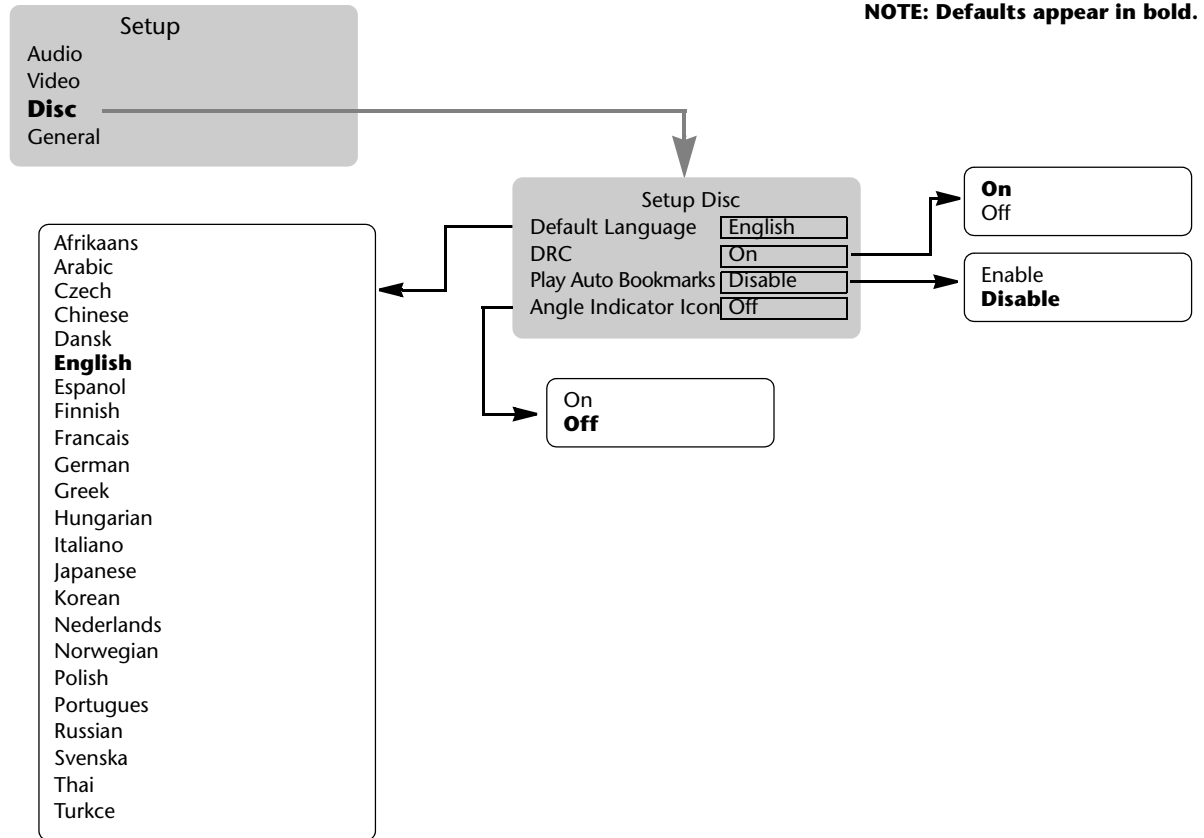





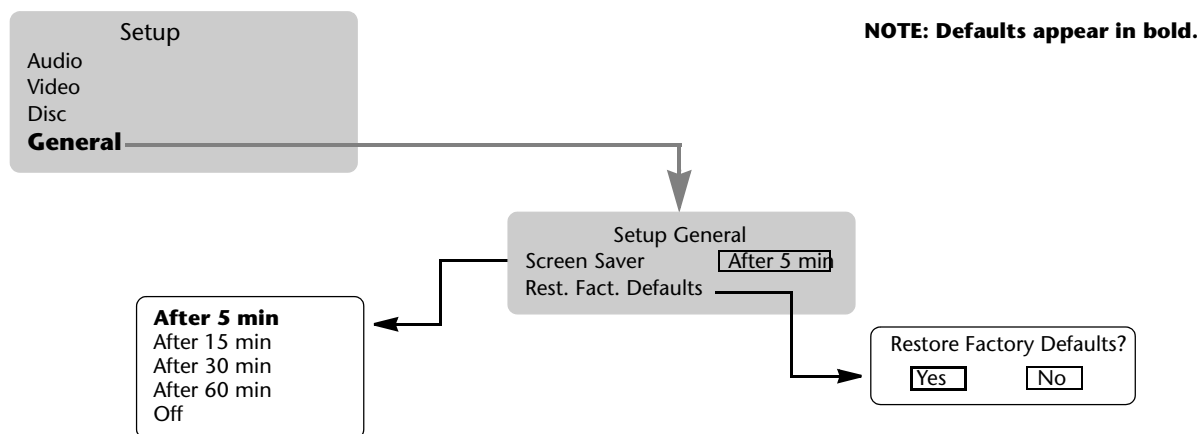





A-7

General Menu Tree

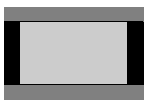

Display Aspect Ratio

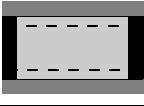
Display Output with Different Combinations of Display Aspect Ratio Settings, DVD Formats and Output Resolutions

	Input			Output	
	Display Aspect Ratio Setting in No51 Setup Menu (see note 1)	Aspect Ratio on DVD	Resolution (see note 2)	Output on Display (see note 3)	Notes
1	16:9	Widescreen (16:9)	SD		See note 4.
			HD		
		Fullscreen (4:3)	SD		
			HD		
5	4:3	Widescreen (16:9)	SD		See note 4.
			HD		
		Fullscreen (4:3)	SD		
			HD		
9	4:3 P&S	Widescreen (16:9)	SD		See notes 4 and 5.
			HD		
		Fullscreen (4:3)	SD		
			HD		

A-8

Notes:

1. The Display Aspect Ratio setting in the N°51 setup menu should always be set to match the aspect ratio of the display device connected to the unit. All display output examples shown assume that this is the case.
2. HD indicates HDMI (switch in down position) with the Resolution set to 720p or 1080i in the N°51 setup menu. SD indicates any analog video (switch in up or middle position), or HDMI (switch in down position) with the Resolution set to SD or PS.
3. Black bars shown are set by the N°51, gray bars are set by the display device.
4. All examples for Widescreen DVDs are shown as 16:9 (1.78:1). For other widescreen formats (such as 2.35:1), black bars will always be present (even on a 16:9 display). For examples that already show black bars, they will be wider when playing a 2.35:1 DVD than they will when playing a 16:9 (1.78:1) DVD.
5. Dotted lines indicate that the display output will depend on the DVD. If auto pan & scan vectors are encoded on the widescreen disc, the display will look the same as a Fullscreen (4:3) DVD. If not, the display will look the same as a Widescreen (16:9) DVD.
6. The Zoom Ratio can be adjusted using the remote control to eliminate or minimize black bars if desired. All examples shown assume that the Zoom Ratio is set to its default setting of Normal.
7. Some display devices also have settings that can affect zoom and aspect ratio. Refer to the TV or display device instruction manual to determine the best setting.

Numerics

2-Ch Downmix option 3-7
 2-channel PCM 3-4, 3-5, 3-6
 5.1 option 3-7
 6-channel analog output connectors 2-7
 8s prev 4-9

A

A/V Sync Delay option 3-12
 A-B repeat 4-13
 adjusting
 color controls using test images 3-29
 convergence 3-30
 display geometry 3-30
 sliders 3-2
 Analog and Component SD Interlaced 3-16
 analog audio configurations 1-6
 analog audio output connectors 2-7
 Analog Audio Preferences 3-7
 Crossover Configuration 3-7
 Levels Calibration 3-9
 Speaker Configuration 3-7
 Speaker Distances 3-8
 Analog Out Stand. Def. parameters 3-26
 Black Level 3-26, 3-27
 Display Aspect Ratio 3-26
 Reset Display Profile 3-26, 3-27
 Video Format 3-26
 Zoom Ratio 3-26
 analog video configurations 1-5
 Angle Indicator Icon parameter 3-32
 assigning
 crossover points 3-8
 Audio CD 4-1, 4-2
 Audio menu tree A-5
 audio performance A-1
 audio processor 1-3
 audio setup 3-3
 AV & RGB mini jacks 2-7

B

black level 3-21
 Black Level parameter 3-26, 3-27
 Bookmarks 4-17

break-in period 1-12
 Brightness parameter 3-16

C

calibrating output levels 3-9
 CD Info status 4-21
 chapter 2-4
 Chroma Sharpness 3-19
 Chroma Sharpness parameter 3-17
 Color Bars test image 3-29
 Color Tint parameter 3-16
 comm port 2-8
 Comp. Out Prog. Scan parameters 3-25
 Display Aspect Ratio 3-25
 Reset Display Profile 3-25
 Zoom Ratio 3-25
 Component Progressive EDTV 3-15
 component video performance A-2
 composite and S-Video performance A-2
 configurations 1-4
 Contrast parameter 3-16
 creating
 a playlist 4-15
 bookmarks 4-17
 Crosshatch test image 3-29
 Crossover Configuration parameter 3-7

D

Declaration of Conformity A-4
 Default Language parameter 3-31
 Default TV Standard option 3-28
 Deinterlacing 3-18
 Deinterlacing PS, HD parameter 3-16
 deleting
 playlist files 4-16
 digital audio output connectors 2-7
 Digital HDMI 3-15
 disc care 1-14
 disc compatibility 1-13
 Disc parameters 3-31
 discs to avoid 1-14
 display aspect ratio
 16
 9 3-23
 4

- 3 3-23
- 3 P&S 3-23
- Display Aspect Ratio parameter 3-22, 3-26
- Dolby Digital parameter 3-3, 3-5
- DRC parameter 3-31
- Dsc menu tree A-7
- DTS parameter 3-4, 3-5
- DTS-CD 4-1, 4-2
- DVD-V 4-1, 4-2
- DVD-V Info status 4-20
- Dynamic Range Control (DRC) 3-31

E

- ED video output switch 2-7, 3-14
- Edit Source Profile option 3-16
- Extended Definition connectors 2-7

F

- Film Mode 3-17
- Film Mode parameter 3-16
- frame-by-frame playback 4-9
- front panel controls
 - 4-way button 2-3
 - display intensity button 2-2
 - drawer 2-3
 - drawer button 2-3
 - menu button 2-3
 - next button 2-2
 - pause button 2-2
 - play button 2-2
 - power button 2-2
 - previous button 2-3
 - return button 2-3
 - setup button 2-3
 - standby button 2-2
 - stop button 2-3
 - top menu button 2-3
- front-panel display 2-3, 2-4
- front-panel overview 2-1
- fwd/rev 4-8

G

- General menu tree A-7
- General parameters 3-33
- getting started 1-1

H

- HD 1080i 3-22
- HD 720p 3-22
- HDCP 3-26

- HDMI Audio Preferences 3-3
 - Dolby Digital 3-3
 - DTS 3-4
 - Enable 3-4
- HDMI configurations 1-4
- HDMI connector 2-8
- HDMI features 3-15
- HDMI output parameters
 - Display Aspect Ratio 3-22
 - Reset Display Profile 3-25
 - Zoom Ratio 3-23
- HDMI output switch 2-7, 3-14
- HDMI video preferences 3-20
 - Display Aspect Ratio 3-20
 - Reset Display Profile 3-20
 - Resolution parameter 3-20, 3-21
 - Video Format parameter 3-20
 - Zoom Ratio 3-20
- high-pass filter 3-7

I

- IEC-standard 2-7
- Info status 4-19
- installation considerations 1-9
- IR input connector 2-8
- isopropyl alcohol 5-4

L

- Levels Calibration option 3-9
- low-pass filter 3-7
- Luma Sharpness 3-19
- Luma Sharpness parameter 3-17

M

- mini-jack 2-8
- monitor connector 2-8
- Mute Level Reduction
 - option 3-12

N

- navigating disc menus 4-1
- Noise Reduction 3-19
- Noise Reduction parameter 3-16
- NTSC 3-28

O

- Outputs
 - Analog Audio 3-7
 - HDMI Audio 3-3

S/PDIF Audio 3-5

P

PAL 3-28

pause button 4-7

PCM Out Rate parameter 3-6

placement 1-9

Play Auto Bookmarks parameter 3-32

play button 4-6

playback modes 4-6

playlist 4-14

playlist requirements 4-15

power connector 2-7

power cord 5-1

power on 1-12

power requirements 1-12

power supply 1-2

Power-On Volume parameter 3-12

product registration 1-9

Progressive Scan 3-22

R

random playback 4-11

rear-panel overview 2-6

region code indicator 2-8

registration 1-9

remote control 2-9

batteries 1-10

remote-control

8S prev button 2-12

A-B button 2-14

angle button 2-14

audio button 2-14

delete button 2-14

drawer button 2-10

enter button 2-12

forward & reverse buttons 2-11

info button 2-14

intens button 2-13

left & right button 2-12

light 2-11

mark/recall button 2-14

mute button 2-14

number buttons 2-13

pause button 2-11

play button 2-11

playlist button 2-14

previous & next buttons 2-12

random button 2-13

ratio button 2-13

repeat button 2-13

return button 2-12

search button 2-14

setup button 2-12

slow forward button 2-13

slow reverse button 2-13

standby button 2-11

stop button 2-12

subtitle button 2-14

top menu button 2-11

up & down buttons 2-11

video button 2-13

volume button 2-14

remote-control functions 2-10

repeat playback 4-12

Reset Audio Settings parameter 3-13

Reset Display Profile parameter 3-27

Reset Source Profile parameter 3-17

resetting

audio settings 3-13

the display profile 3-25, 3-27

Rest. Fact. Defaults parameter 3-33

restoring default settings 5-3

restoring factory settings 3-33

Resume mode 4-7

RGB Expand parameter 3-20

RGB Normal parameter 3-20

RS-232 ports 2-8

S

S/PDIF Audio Preferences 3-5

Dolby Digital 3-5

DTS 3-5

Enable 3-6

PCM Out Rate 3-6

Saturation parameter 3-16

Screen Saver parameter 3-33

SD video output switch 2-7, 3-14

SD/ED component video output connectors 2-7

search 4-10

Select Source Profile option 3-16

selecting

a camera angle 4-4

a default language 3-31

a display aspect ratio 3-23

a PCM output rate 3-6

a resolution 3-21

a subtitle language 4-3

a video format 3-20, 3-26

an audio format 3-3, 3-4, 3-5

an audio track 4-3

setting

automatic bookmarks 4-17

black level compensation 3-27

manual bookmarks 4-17

- Mute Level Reduction *3-12*
 - output trim levels *3-10*
 - power-on volume *3-12*
 - the default TV standard *3-28*
 - the default volume *3-11*
- Setup menu navigation *3-1*
- slow fwd/rev *4-8*
- sorting playlist files *4-16*
- Speaker Distances option *3-8*
- specifications *A-1*
- Standard Definition *3-22*
- Standard Definition connectors *2-7*
- Standby *1-12*
- stop button *4-7*
- S-Video & composite video output connectors *2-7*

T

- test image
 - before using *3-29*
 - Color Bars *3-29*
 - Crosshatch *3-29*
- title *2-4*
- track *2-4*
- transport *1-1*
- trigger input connector *2-8*
- trigger outputs *2-7*
- troubleshooting
 - if all else fails *5-3*
 - no HDMI output *5-2*
 - no main output *5-2*
 - no power *5-1*
 - no remote control operation *5-1*
 - no video output *5-2*

U

- unpacking *1-9*

V

- ventilation *1-9*
- Video Format parameter *3-26*
- Video menu tree *A-6*
- video output switch *2-7, 3-14*
- video processor *1-2*
- video resolution
 - HD 1080i *3-21*
 - HD 720p *3-21*
 - PS *3-21*
 - SD *3-21*
- video setup *3-14*
- Volume Control option *3-11*
- Volume Control parameters
 - Mute Level Reduction *3-12*
 - Power-On Volume *3-12*
 - Volume *3-11*

W

- warm-up *1-12*
- writable media *1-13*

Y

- YCbCr *3-20*

Z

- Zoom Ratio
 - Fill *3-24, 4-5*
 - Fill + Wide *3-24, 4-5*
 - Normal *3-24, 4-5*
 - Widescreen *3-24, 4-5*
- Zoom Ratio option *3-23*



3 Oak Park, Bedford, MA, 01730-1413 USA | Telephone: 781-280-0300 | Fax: 781-280-0490 | www.marklevinson.com

Customer Service Telephone: 781-280-0300 | Sales Fax: 781-280-0495 | Service Fax: 781-280-0499

Product Shipments: 16 Progress Road, Billerica, MA 01821-5730 USA

Part No. 070-17143 | Rev 0 | 03/06